

USER MANUAL:
Battery-powered radio wind/sun sensor

593.K.XB.00

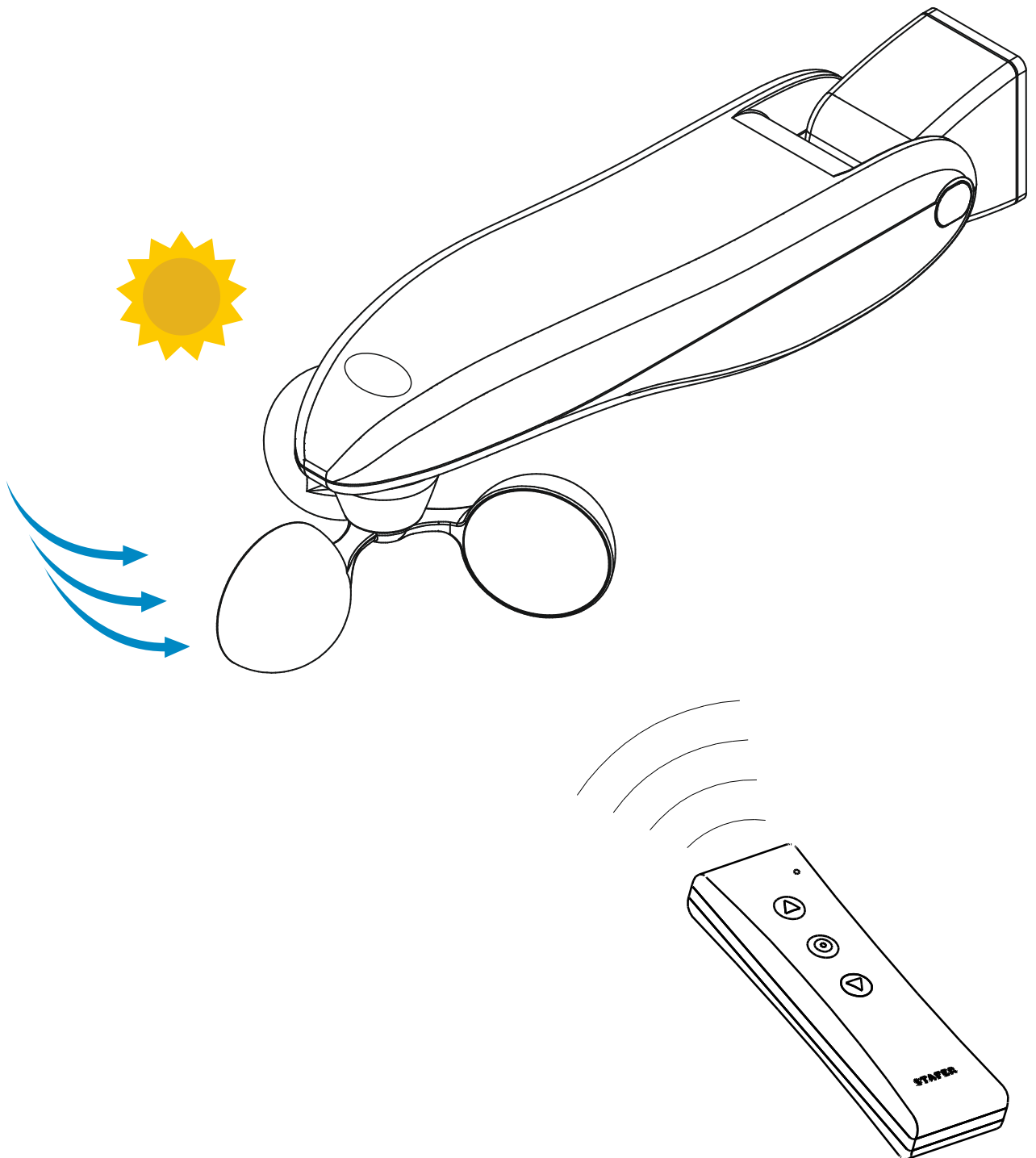

VEGA BT

Dear customer, thank you for purchasing a STAFER product. This guide contains information about the product use. Before the product installation and use, please read carefully this guide and keep it for future reference.

593.K.XB.00 is a radio wind/sun sensor powered by battery and studied to command tubular motors with radio receiver (integrated or external), powered by main voltage and it is suitable to command awnings, roller shutters or similar.

593.K.XB.00 permits to command the automatic upward movement of the blinds connected to the motor when the wind exceeds the set threshold and to command an automatic lowering when the intensity of sun exceeds the set threshold. These thresholds are set by the factory, but they can be adjusted according to the needs.

Warning



This sensor does not protect awning in case of strong and sudden gusts of wind.

In case of weather hazards of this type, make sure that the curtains remain closed!

Master S.p.A. declines all responsibility for damage incurred due to weather events not detected by the device.



Any other use beyond the field defined by Stafer S.p.A. is prohibited and involves, as well as the failure to comply with instructions provided in this guide, the cancellation of Stafer S.p.A. liability and warranty.

The installer, after the installation of the product, must teach the end user about the working way of the automation and provide him with the user manual.

Technical specifications

✓ Power supply:	3V batteries
✓ Battery life (estimate)	3 years
✓ Dimensions:	236 x 54 x 73 mm
✓ Weight:	200 gr
✓ Working temperature:	from -20 to +55 °C
✓ Wind threshold:	from 5 to 35 Km/h (step of 5 Km/h)
✓ Sun threshold:	from 1 to 45 Klux (step of 8 Klux)
✓ Frequency:	433.42 Mhz
✓ Range (estimate):	100m outdoor, 20m indoor

Index

01 Warning	pag. 01
02 Assembly instruction	pag. 02
03 How to turn on the sensor	pag. 03
04 Memorization/deletion of 593.K.XB.00 in a motor (or receiver)	pag. 03
05 Wind sensor	pag. 03
06 Sun sensor	pag. 04
07 Charge status of the battery	pag. 04
08 Replacement of the battery	pag. 05
09 FAQ	pag. 05

Notes on radio system

It is advisable **to avoid using radio systems in areas with strong interference** (for example, near police stations, airports, ports, hospital, etc.). A technical inspection is in any case advisable before installing any radio system in order to identify sources of interference.

Radio systems can be used where possible disturbances or malfunctioning of the transmitter or the receiver do not cause a risk factor, or if the risk factor is cancelled by suitable safety systems.

The presence of radio device operating on the same transmission frequency (**433,42 MHz**) can interfere with the radio receiver of the motor and so reduce the range of the system and limit the functionality of the installation.



Environmental conservation!!

STAFER uses packaging recyclable materials. Dispose materials on the proper containers, complying with the law in force in your locality.

This product may have substances that are polluting for the environment and dangerous for the health.

At the end of the product life cycle, carefully comply with the waste disposal rules. It is strictly forbidden to dispose the product on the domestic waste.



01. WARNINGS. PAY ATTENTION!

Important safety instructions!

01.1 WARNING FOR SAFETY

- ✓ Incorrect installation can cause serious injuries.
- ✓ Keep these instructions for future maintenance work and disposal of the product.
- ✓ All the product installation, connection, programming and maintenance operations must be carried out only by a qualified and skilled technician, who must comply with laws, provisions, local regulations and the instructions given in this manual.
- ✓ The wiring must comply with current CEI standards. The final electrical system must be created only by the electrician.
- ✓ Some applications require hold-to-run operation and can exclude the use of radio controls or require particular safety devices.
- ✓ To prevent potentially dangerous situations, check the operating condition of the roller shutter/awning regularly.

01.2 WARNINGS FOR INSTALLATION

- ✓ Read the technical specifications on the paragraph "Technical specifications" to evaluate the operating limits of the product.
- ✓ Before installing the product, check the compatibility with the associated devices and accessories.
- ✓ Check that the package is intact and has not been damaged in transit.
- ✓ A heavy shock and the use of unsuitable tools can cause the damage of the external or internal parts of the product.
- ✓ Do not pierce or tamper with the product in any way. Do not modify or replace parts without the manufacturer's permission.
- ✓ Check that the place chosen for the installation of the product permits the same wind exposure of the blind to be automated.
- ✓ Check that the place chosen for the installation is made by solid material and can ensure a stable fixation.
- ✓ Check that the place chosen for the installation of the sensor is within the range of transmission-reception generated by the sensor and by the receiver of the blind to be commanded. Although the range in favorable conditions (open field) can be 100m, it is advisable to not exceed 20-30m. It is also advisable to check that there are no other radio devices working at the same frequency or with continuous transmission on the same area, such as alarms, radio headphones, etc...: these could further reduce the range.
- ✓ If there are several radio appliances in the same system, they must not be less than 1,5m apart.
- ✓ Do not install the product near metal surfaces.
- ✓ Do not install the product near heat sources (such as chimneys, etc...).
- ✓ Adjust the inclination of the device to have the blades positioned horizontally.
- ✓ The blades for the wind detections must be faced downward. The blades must be free to rotate without obstruction.
- ✓ Check that the device is placed in a protected position from accidental impact with other object (e.g. branches, etc.).
- ✓ The power cable must be positioned in such a way that it does not come into contact with moving parts.
- ✓ Do not use abrasive or solvent product for cleaning the device; do not clean using water or high-pressure cleaners.
- ✓ For your safety, do not work near the winding roller while the motor is powered.

01.3 WARNINGS FOR USE

- ✓ The product is not intended to be used by persons (including children) with reduced physical, sensory or mental capabilities, or lack of experience and knowledge, unless they are supervised or given instructions about the product way of use by a person responsible for their safety.
- ✓ Check the automation during the movement and keep people at a safe distance, until the movement ends.
- ✓ Do not allow children to play with the appliance or with the fixed control devices.
- ✓ Do not operate the blind when maintenance operations are being carried out (e.g. window cleaning, etc.). If the control device is automatic, disconnect the motor from the power line.

02. ASSEMBLY INSTRUCTIONS

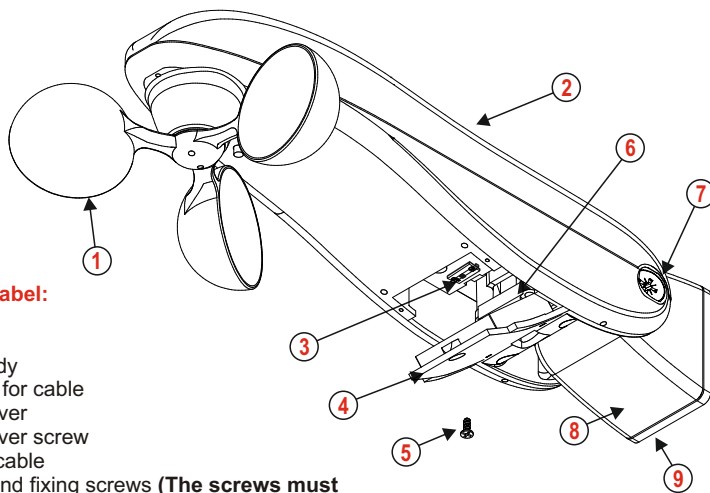

Components label:

- (1) Blades
- (2) Sensor body
- (3) Connector for cable
- (4) Closing cover
- (5) Closing cover screw
- (6) Retaining cable
- (7) Adjusting and fixing screws **(The screws must never be completely unscrewed)**
- (8) Wall fixing
- (9) Wall support

02.1 BUTTONS AND LEDs

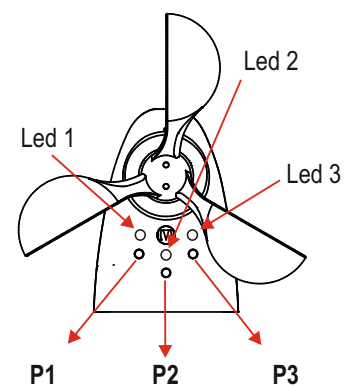

02.2 FIXING SYSTEM

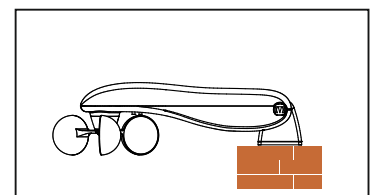
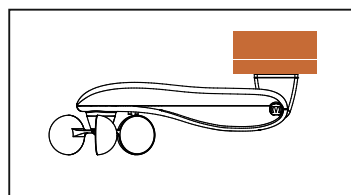
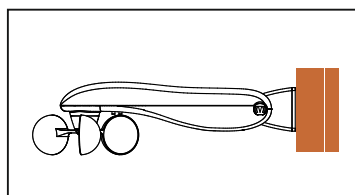
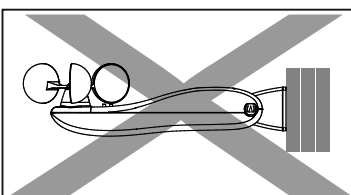

02.3 MOUNTING INSTRUCTIONS



WARNING: Adjusting and fixing screws (7) must never be completely unscrewed

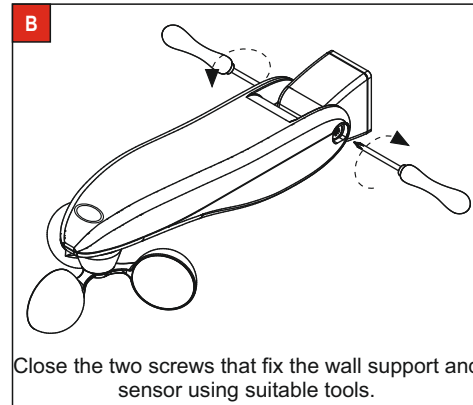
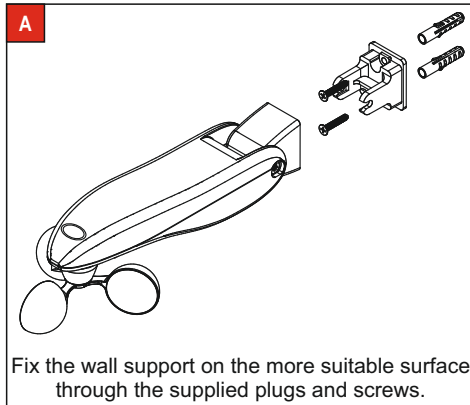

Notes:

- ✓ the product has been studied to be installed with the blades facing downward. Moreover, the body sensor must be adjusted horizontally (the use of a bubble level can simplify the operation); the wall bracket with tilting angle $\pm 90^\circ$ allows to mount the sensor even on no-vertical structures.
- ✓ the hole interaxis is 30 mm.

03. HOW TO TURN ON THE SENSOR

To power the radio sensor, you must open the closing cover [4], slide the switch [3] from the OFF (or 1) to the ON position and see if LED1 lights briefly.



Warning:

If LED1 do not turn on, return the switch to the OFF position (or 1), wait a few seconds and repeat.

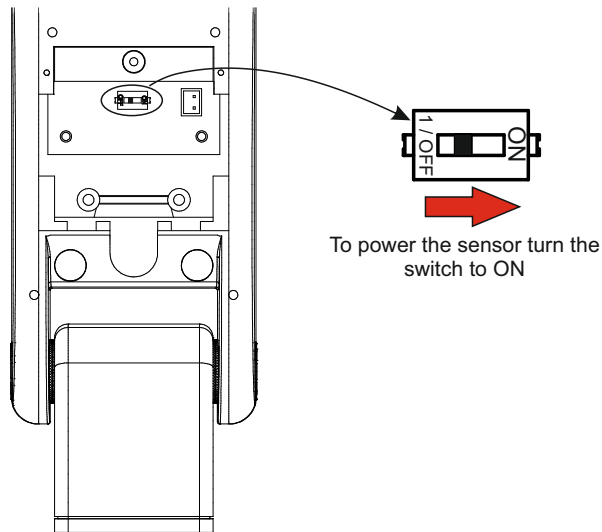

04. MEMORIZATION/DELETION OF 593.K.XB.00 IN A RECEIVER/MOTOR

The procedure to memorize or delete 593KXB00 in a receiver depends on the receiver, but usually is the following:

- with the transmitter bring the motor/receiver to the intermediate position.
- press PROG on the transmitter (with 594.T.X... in the battery compartment. / with 593.T.X1.00 in the back in the hole) for around 5 seconds to let the motor/receiver enter into the programming (the motor/receiver makes a signal)
- press P1 on 593KXB00 and hold it until the motor/receiver confirmation movement.

To verify that the sensor is properly memorized, bringing the tuned receivers to the middle position, rotate the vane of the anemometer quickly to simulate the condition of "wind alarm". The tuned receivers have to move uphill and their manual controls must be inhibited. To exit from "wind alarm", press any button on the body of the radio sensor for about 3 seconds, until the LEDs light up briefly, then release the button.

IMPORTANT NOTE

If to receiving device is lacking the supply voltage, at power ON the sensor and the radio receiving device can take up to 10 minutes to re-establish the radio communication

05. WIND SENSOR

If the wind speed is above the set threshold for at least 3 seconds, an upward movement is commanded to protect the awning (wind alarm). During this phase **all manual commands are disabled**. The device exits from the "wind alarm" if the wind speed keeps below the set threshold for at least 8 minutes. The wind threshold is varying from 5 km/h to 35 km/h. The factory sets the wind threshold at 15 Km/h. **IMPORTANT: you can not make these adjustments from a remote control!**

05.1 WIND THRESHOLD ADJUSTING THROUGH THE BUTTONS ON THE DEVICE

A

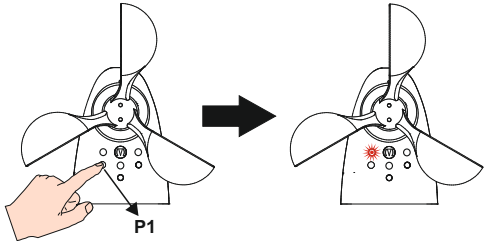

n° of flashes	threshold
1	10 Km/h
2	15 Km/h
3	20 Km/h
4	25 Km/h
5	30 Km/h
6	35 Km/h

Press P1 until LED 1 starts to flash, signalling the current wind threshold

If the value is the desired one, wait 10 seconds: the device signals again the value and exits from the programming.

B ⁽¹⁾ TO ADJUST THE WIND THRESHOLD:
Press P1 (see table) to set the new value

EXAMPLE:

4 X

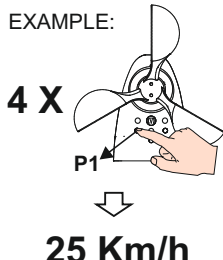

25 Km/h

EXAMPLE:

1 X

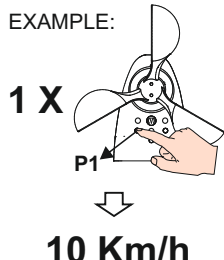

10 Km/h

C

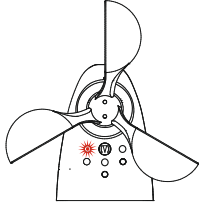

n° of flashes	threshold
1	10 Km/h
2	15 Km/h
3	20 Km/h
4	25 Km/h
5	30 Km/h
6	35 Km/h

The device signals the new value and exits from the programming

Notes:

- ✓ (1) : press the buttons within 10 seconds from the last flash of LED 1. The buttons must be shortly pressed, around 1 second between two pressures. Press the buttons the same number of time of the desired value.
- ✓ If you try to set a wind threshold higher than 35 Km/h, the device signals the error with the lighting of the 3 leds for 3 times.

05.2 VISUAL SIGNALS ASSOCIATED WITH THE WIND SENSOR

In order to preserve battery life, no visual indication is performed during normal operation. Only when a transmission is sent due to the modification of a weather condition (by presence at the absence of wind or vice versa), the red LED lights up briefly.

06. SUN SENSOR

The device operates by sending a transmission of presence of the sun when the sun intensity exceeds the set threshold for at least 2.5 minutes, intervenes by sending a transmission of the absence of sun if the intensity of the sun is below the set threshold for a period between 12 and 18 minutes (this value varies depending on the speed with which the brightness decreases). During wind alarm the sun sensor is inhibited. The sun threshold is variable from 1 to 45 Klux. The factory sets the threshold at 15 Klux sun (level 3). **IMPORTANT: you can not make these adjustments from a remote control!**

A

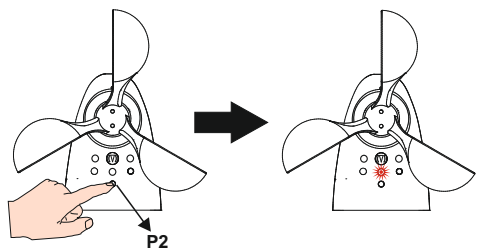

n° of flashes	threshold
1	1 Klux
2	8 Klux
3	15 Klux
4	22 Klux
5	30 Klux
6	45 Klux

Press P2 until LED 2 starts to flash, signalling the current sun threshold

If the value is the desired one, wait 10 seconds: the device signals again the value and exits from the programming.

B TO ADJUST THE SUN THRESHOLD:
Press P2 (see table) to set the new value

EXAMPLE:

4 X

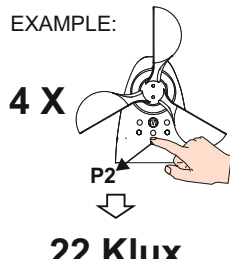

22 Klux

EXAMPLE:

1 X

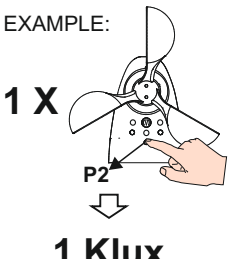

1 Klux

C

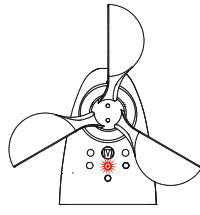

n° of flashes	threshold
1	1 Klux
2	8 Klux
3	15 Klux
4	22 Klux
5	30 Klux
6	45 Klux

The device signals the new value and exits from the programming

06.3 CHECK OPERATION OF SENSORS

Press together the onboard buttons P2 and P3 for about 5 seconds until only LED1 lights up, then release the buttons. By rotating the vanes LED1 should turn off and LED 2 lights up. Illuminate the sun sensor using a portable torch. Verify that the LED2 turns off when the sensor is reached by warm light of portable torch. Obscure the sun sensor and verify that the LED2 turns on. After about 8 seconds, the sensor will automatically exit the test of the sun sensor. You can exit test at any time by briefly pressing P1.

07. CHARGE STATUS OF THE BATTERY

It's possible, if necessary, know the level of charge of the battery. It's useful, in fact, replace the battery before it runs out definitively, so as to ensure the continuous operation of the sensor. The procedure is as follows:

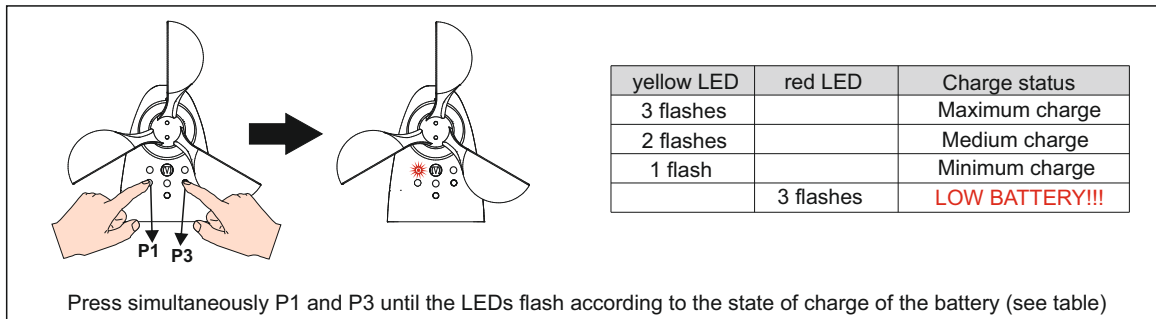

yellow LED	red LED	Charge status
3 flashes		Maximum charge
2 flashes		Medium charge
1 flash		Minimum charge
	3 flashes	LOW BATTERY!!!

Press simultaneously P1 and P3 until the LEDs flash according to the state of charge of the battery (see table)

The battery life is estimated to be at least 3 years in standard conditions of temperature and humidity. However, you must consider the fact that the battery life can be reduced in particular conditions of use.

Where available, it is strongly recommended to keep active, in the radio receivers tuned to the sensor, the "Test radio" function. If, due to the gradual depletion of the battery, the transmission range of sensor is no longer enough to reach a tuned receiver, the "Test Radio" of the receiver periodically (about every 30 minutes) rewinds the awning, bringing it in safe position and providing a visible indication of the need to check the radio sensor and eventually replace the battery.

While waiting for the necessary checks by an authorized technician, you can temporarily disable the "Test Radio" as described on the installation manuals of the receivers.

08. REPLACEMENT OF THE BATTERY



Battery replacement must be performed by an authorized technician, following all applicable safety standards.

The battery must be replaced by an equivalent type. Contact an authorized installer for the replacement battery. Because of the conditions of use of the sensor, the temperature inside the sensor can reach high values. Inadequate batteries may cause fire or explosion.

How to replace the battery:

- remove the closing cover.
- slide the switch to OFF (or 1).
- remove the old battery and replace it with the new battery supplied by the manufacturer of the sensor.
- slide the switch to ON.

The old battery must be disposed of in the appropriate containers.

After replacing the battery is required to perform a verify of the system. In the event that the system does not work, set the switch to OFF, wait a few seconds, return the switch to ON and check that the LED1 lights up briefly, and then redo the verify operation of the sensor. In cases where receivers have disabled the "Test Radio", you should re-enable it.

09. FAQ

THE SENSOR DOES NOT PERFORM ANY OPERATION

- ✓ Check the battery status. If exhausted replace it.
- ✓ Once powered, LED1 lights up briefly to indicate the turning ON. If this is not done, return the switch to OFF (or 1), wait a few seconds and slide the switch ON.

IN PRESENCE OF WIND, THE UPWARD MOVEMENT IS NOT COMMANDED

- ✓ Wind threshold is too high. Adjust the threshold.
- ✓ The device could be installed in a position little exposed to the wind.
- ✓ The wind sensor may be damaged. Use the procedure 05.3 to check the operation of the sensor.
- ✓ Interferences on Radio connection. Verify that there are no interferences on same frequency.

IN PRESENCE OF WIND, THE UPWARD MOVEMENT IS COMMANDED BUT IN PRESENCE OF SUN THE DOWNWARD MOVEMENT IS NOT COMMANDED

- ✓ The device is in "Wind alarm".
- ✓ Sun threshold is too high. Adjust the threshold.
- ✓ The device could be installed in a position little exposed to the sun, or some object obstructs the proper detection of the sun.
- ✓ Sun function is deactive.
- ✓ The sun sensor may be damaged. Check functionality by procedure 06.3



All rights reserved.
STAFER S.p.a. - via Malpighi, 9 - 48018 Faenza (RA) ITALY
Tel. (+39) 0546.624811 - Fax. (+39) 0546.623141 - www.stafer.com



All products and technical specifications given in this document are subject to variation without notice. Unless previously and specifically authorised by STAFER, the device must be used exclusively with transmitters produced by STAFER.

STAFER cannot be considered responsible for damage caused by improper, incorrect or unreasonable uses.