



## User manual for 590.C.SM.00 centralization module

### WARNINGS



Dear Customer, thank you for purchasing a STAFER spa product.

This guide contains all the information you will need concerning the use of this product. Read the instructions carefully and keep them for further consultation. The module 590.C.SM.00 is specially designed for the control of a tubular motor with **mechanical limit switches**. All other use beyond the field defined by STAFER S.p.A. is forbidden. This, as well as the breach of the instructions given in this guide, shall release STAFER S.p.A. from any liability and shall annul the product warranty.

### DISPOSAL



At the end of the product life cycle, dispose of the device in compliance with local regulations. This product could contain substances that are harmful to human health and the environment: do not dispose of the product in domestic waste.



### 1. TECHNICAL SPECIFICATIONS

Power supply :	120 o 230 Vac 50/60 Hz	Operating time :	from 1 s to 250 s
Contact capacity :	10 A@250 Vac	Dimensions :	44 x 38 x 25 mm
Grade of protection :	IP20	Operating temperature :	from -20°C to +55°C

### 2. WARNINGS ON SAFETY



- All the product installation, connection, programming and maintenance operations must be carried out only by a qualified and skilled technician, who must comply with laws, provisions, local regulations and the instructions given on this manual.
- Check that the package is intact and has not suffered damages in transit
- Make connections with power supply disconnected
- Adjust the limit switches of the motor before connecting it to the module
- Use momentary (hold-to-run) control buttons. Do NOT use stay-put switches. Command buttons are connected to the main voltage, so they must be properly insulated and protected. Position the buttons with sight of the roller shutter/awning but a long way from its moving parts. Position the buttons more than 1.5 m from the floor
- You cannot connect more than one motor directly to the module. If it is necessary to connect more than one motor to the module use the appropriate expansion cards.
- The supply line must be equipped with a circuit breaker. The installer must fit an isolation device (with 3,5 mm minimum opening on the contacts) upstream of the system
- Do not modify or replace parts without the manufacturer's permission.
- For your safety, do not work near the winding roller while the motor is powered
- The product is designed to be inserted inside of junction boxes. The module does not provide any protection against water and only essential protection for contact with solids. It is forbidden to install the module in areas not adequately protected, near sources of heat
- Check that the power supply does not depend from electrical circuits for lighting
- The product doesn't provide any protection against overloads or short circuits. You must provide, on the supply line, an adequate protection to the load, for example a fuse of maximum value 3,15 A

#### 2.1. Power supply



The module can be powered at 120 Vac or 230 Vac. The supply voltage must be applied to terminals 1 and 2.

#### 2.2. Connecting the motor



The motor windings must be connected to the terminals 7 and 8, the common wire of the motor must be connected to terminal 1. You can not connect more than one motor directly to the module. If it is necessary to connect more than one motor to the module use the appropriate expansion cards.

#### 2.3. Connecting the S single commands buttons



The single command buttons must be connected to terminals 5 and 6, the common thread of the buttons must be connected to terminal 1. The command buttons are subject to the mains voltage and therefore must be properly insulated and protected. You must use momentary (hold-to-run) button, do not use buttons with maintained position. More than one command button can be connected to the unit through a parallel connection. For the correct operation of the system it is necessary to check that the closure of the button connected to terminal 6 (▲ S, up single) matches the upward movement of the motor, if not, invert the wires of the motor windings to the terminals 7 and 8.

#### 2.4. Connecting the G general commands buttons



The general command buttons must be connected to terminals 3 and 4 and must close on terminal 1. You must use momentary (hold-to-run) button, do not use buttons with maintained position. More general command buttons can be connected via a parallel connection.

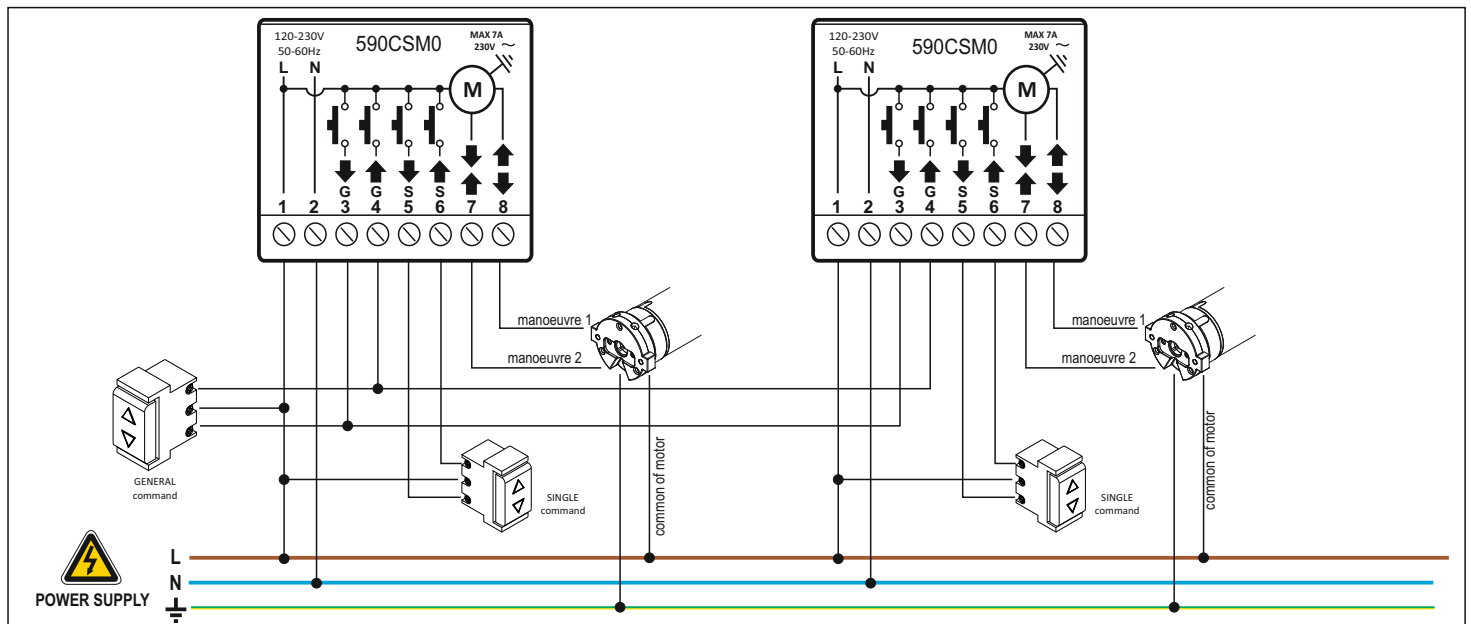

### 3. OPERATING LOGIC OF THE BUTTONS

Single and general command buttons can operate in two different operating logics: "impulse" mode or "hold-to-run" mode. The procedure to select the operating logic of the buttons is described in Section 4.4 ("selection of the operating logic of the buttons"). **The factory sets the buttons in the "impulse" mode.**

**"Impulse" mode:** to perform a single command up or down, press the corresponding button for at least 0.5 seconds, to stop the manoeuvre briefly press any of the command buttons (single or general). To perform a general command up or down, press the corresponding button for at least 0.5 seconds, to stop the manoeuvre briefly press any of the command buttons (single or general). The upward and downward general manoeuvres will be performed in compliance with the switch-on delay, as explained in section 4.2 ("insertion delay on the general command").

**"Hold-to-run" mode:** to perform a single or general command, up or down, press the corresponding button, the operation will stop when the button is released. If the buttons work in this logic the "insertion delay on the general command" function and the "air change" function are not available.

### 4. PROGRAMMING MENU

Through the programming menu you can set some functions of the module.

#### 4.1. Operating time

The module provides the ability to program the operating time (time needed to bring the motor from the lower end position to the upper end position). The factory sets the operating time of 130 sec. The operating time can vary from a minimum of 1 sec to a maximum of 250 sec.

##### How to set the operating time:

- Bring the motor in an intermediate position.
- Disconnect the power to the module and wait a few seconds. Connect the power to the module.
- Within 15 sec press briefly 5 times (less than 0.5 sec) in quick succession the ▼S button. The motor makes 3 upward movements.
- Press briefly ▲ S. The motor performs a downward manoeuvre. Wait until the motor stops for the intervention of the previously set mechanical limit switch.
- Press briefly ▲ S. The motor performs an upward manoeuvre. Wait until the motor stops for the intervention of the previously set mechanical limit switch.
- Press briefly ▲ S. The module saves the operating time and indicates the operation with an alternate movement of the motor (downwards and upwards).

BRING THE MOTOR IN AN INTERMEDIATE POSITION

DISCONNECT POWER SUPPLY

WAIT 2 sec.

CONNECT POWER SUPPLY

press DOWN 5 times

THE MOTOR MAKES 3 UPWARD MOVEMENTS

press UP 1 times

WAIT UNTIL MOTOR STOPS ON LOWER LIMIT SWITCH

press UP 1 times

WAIT UNTIL MOTOR STOPS ON UPPER LIMIT SWITCH

press UP 1 times

OPERATING TIME SAVED

#### 4.2. Insertion delay on general command

The module is equipped with inputs for the general command. In the event that it is necessary to distribute the start of motors to avoid overloading the power line, you can use this function. The general commands (upward or downward) will be performed from the module after the selected delay. The factory sets the "insertion delay on the general command" at value 1 (00 seconds = immediate start).

##### How to modify the insertion delay :

- Bring the motor in an intermediate position.
- Disconnect the power to the module and wait a few seconds. Connect the power to the module.
- Within 15 sec press briefly 5 times (less than 0.5 sec) in quick succession the ▼S button. The motor makes 3 upward movements.
- Press briefly ▼S. The motor returns to its initial position and performs 4 upward movements.
- Press briefly ▲S. The module performs a number of upward movements equal to the currently set value (see table).
- If you want to modify the setting, press briefly ▲S a number of times equal to the desired value (see table).
- After approximately 8 seconds, the module displays the setting and return to normal activities.

Movements of the motor	Insertion delay
1 movement	00 seconds
2 movements	10 seconds
3 movements	20 seconds
4 movements	30 seconds
5 movements	40 seconds
6 movements	50 seconds

BRING THE MOTOR IN AN INTERMEDIATE POSITION

DISCONNECT POWER SUPPLY

WAIT 2 sec.

CONNECT POWER SUPPLY

press DOWN 5 times

THE MOTOR MAKES 3 UPWARD MOVEMENTS

press DOWN 1 times

THE MOTOR MAKES 4 UPWARD MOVEMENTS

press UP 1 times

THE MODULE PERFORMS A NUMBER OF UPWARD MOVEMENTS EQUAL TO THE CURRENTLY SET VALUE (see table)

TO MODIFY PRESS UP A NUMBER OF TIMES EQUAL TO THE DESIRED VALUE (see table).

### 4.3. «Air change» function

If the module is used for the movement of roller shutters, it can be useful to activate this function. Pressing briefly for 2 times (less than 0.5 sec) in quick succession button ▼S, the module lowers the roller shutter and, at the end of working time, it commands a small upward movement, such as to permit ventilation.

Pressing briefly for 2 times (less than 0.5 sec) in quick succession the ▼G button the operation will affect all the roller shutters wired to the General button and will be followed in respect of the insertion delay on the general command. The duration of short upward movement can be set according to the size of the roller shutter. The factory sets the function "air change" to the value 1 (INACTIVE).

#### How to set the duration of the small upward movement:

- Bring the motor in an intermediate position.
- Disconnect the power to the module and wait a few seconds. Connect the power to the module.
- Within 15 sec press briefly 5 times (less than 0.5 sec) in quick succession the ▼S button. The motor makes 3 upward movements.
- Press briefly ▼S. The motor returns to its initial position and performs 4 upward movements.
- Press briefly ▼S. The motor returns to its initial position and performs 5 upward movements.
- Press briefly ▲S. The module performs a number of upward movements equal to the currently set value (see table).
- If you want to modify the setting, press briefly ▲S a number of times equal to the desired value (see table).
- After approximately 8 seconds, the module displays the setting and return to normal activities.

Movements of motor	«Air change» function
1 movement	INACTIVE
2 movements	01 second
3 movements	02 seconds
4 movements	03 seconds
5 movements	04 seconds
6 movements	05 seconds

BRING THE MOTOR IN AN INTERMEDIATE POSITION

DISCONNECT POWER SUPPLY

WAIT 2 sec.

CONNECT POWER SUPPLY

press DOWN 5 times

THE MOTOR MAKES 3 UPWARD MOVEMENTS

press DOWN 1 times

THE MOTOR MAKES 4 UPWARD MOVEMENTS

press DOWN 1 times

THE MOTOR MAKES 5 UPWARD MOVEMENTS

press UP 1 times

THE MODULE PERFORMS A NUMBER OF UPWARD MOVEMENTS EQUAL TO THE CURRENTLY SET VALUE (see table)

TO MODIFY PRESS UP A NUMBER OF TIMES EQUAL TO THE DESIRED VALUE (see table).

### 4.4. Operating logic of the buttons

- Bring the motor in an intermediate position.
- Disconnect the power to the module and wait a few seconds. Connect the power to the module.
- Within 15 sec press briefly 5 times (less than 0.5 sec) in quick succession the ▼S button. The motor makes 3 upward movements.
- Press briefly ▼S. The motor returns to its initial position and performs 4 upward movements.
- Press briefly ▼S. The motor returns to its initial position and performs 5 upward movements.
- Press briefly ▼S. The motor returns to its initial position and performs 6 upward movements.
- Press briefly ▲S. The module changes the setting and indicates the operation with an alternate movement of the motor (downwards and upwards).

BRING THE MOTOR IN AN INTERMEDIATE POSITION

DISCONNECT POWER SUPPLY

WAIT 2 sec.

CONNECT POWER SUPPLY

press DOWN 5 times

THE MOTOR MAKES 3 UPWARD MOVEMENTS

press DOWN 1 times

THE MOTOR MAKES 4 UPWARD MOVEMENTS

press DOWN 1 times

THE MOTOR MAKES 5 UPWARD MOVEMENTS

press DOWN 1 times

THE MOTOR MAKES 6 UPWARD MOVEMENTS

press UP 1 times

THE MOTOR MAKES AN ALTERNATE MOVEMENT TO INDICATE THE MODIFICATION OF THE SETTING

