





**FINO A
10 ANNI
DI GARANZIA**
UP TO
10 YEARS
WARRANTY



**MOTORIDUTTORI
E AUTOMATISMI**
TUBULAR MOTORS
AND CONTROLS



Legenda dei simboli - Key to symbols

	Diametro del motore Diameter of the motor
	Funzioni specifiche e controlli per tende da sole Specific functions and controls for awnings
	Reset da radiocomando (oltre alla modalità da cavi elettrici) Reset by radio transmitter (in addition to the mode by electric cables)
	Funzione di inversione del terzo finecorsa con il finecorsa inferiore (in qualsiasi momento, utile per tapparelle orientabili in base alle proprie esigenze) Function of inverting the third limit switch with the lower limit switch (at any time, based on your needs, useful for louvre rolling shutters)
	Funzione di inversione del senso di rotazione (in caso di programmazione errata del radiocomando si evita il reset e la programmazione) Reverse direction function (in case of incorrect programming of the remote control, reset is avoided)
	Funzione di arresto automatico in caso di ostacolo in salita (sia in partenza nel caso di catenaccioli, sia in qualsiasi punto durante la salita) Function of automatic obstacle detection when ascending (both at the start in case of shoot bolts and at any point during the ascent)
	N°2 Finecorsa meccanici 2 mechanical end strokes
	N°3 Finecorsa elettronici 3 electronic limit switches
	Funzione micromovimenti per stecche orientabili (rotazione stecche tipo persiana) Micromovement function for tilting slats (slat tilting in louvre rolling shutters)
	Funzionante sia con radiocomando che con pulsante (opzionale) Working with both radio transmitter and button (optional)
	Pulsante a uomo presente o impulso (è possibile programmare lo stesso pulsante nei 2 modi diversi in base alle proprie esigenze) Manned or pulse button (you can program the same button in these 2 distinct ways based on your needs)
	Programmabile da pulsante o radiocomando (tutte le programmazioni sono fattibili da radiocomando o da pulsante come anche l'utilizzo delle varie funzioni) Programmable by either push-button or radio transmitter (all the programming can be done by either remote control or push-button, as well as the use of the various functions)

Garanzia - Warranty

	<p>10 anni per motori serie V6, VM6, V7, VM7, V7s</p> <p>10 years as regards the motors of the series V6, VM6, V7, VM7, V7s</p>
	<p>5 anni per motori serie V4, V6 RX.3, VM6 RX.3, V6 RX.E3, V7 RX.3, V7 RX.E3</p> <p>5 years as regards the motors of the series V4, V6 RX.3, VM6 RX.3, V6 RX.E3, V7 RX.3, V7 RX.E3</p>
	<p>2 anni per tutti gli altri prodotti</p> <p>2 years as regards all the other products</p>

Caratteristiche generali - General features

- Ogni motore radio è collegabile ad un pulsante senza l'ausilio di centraline
- Nei motori non radio il pulsante è a uomo presente, solo con centraline il pulsante può diventare ad impulso
- Centralizzazioni e gruppi con motori radio si ottengono con radiocomando senza centraline (nel caso ci siano anche pulsanti possibilità di inserire centraline)
- I motori Stafer sono compatibili con impianti domotici ed impianti di Smart home
- Each radio-controlled motor can be connected to a button without the aid of control units
- In non-radio-controlled motors, the button is man-operated. The button can only become pulse by using control units
- You can make centralizations and create groups by radio transmitter without the aid of control units (in case buttons need to be used as well, it is possible to use control units)
- Stafer motors are compatible with home automation systems and Smart home systems



Alimentazione Power supply	230Vac / 50Hz
Tempo di funzionamento continuo Continuous operating time	4 min
Grado di protezione Protection degree	IP 44
Cavo di alimentazione per motori V4 Power input cable for motor V4	4 x 0,50 mm ² - L=2m
Cavo di alimentazione per motori V6 - V7 Power input cable for motor V6 - V7	4/5 x 0,75 mm ² - L=2,5m
Classe di isolamento motori serie V4 - V6 Insulation class for motor V4 - V6	H
Classe di isolamento motori serie V7 Insulation class for motor V7	F
Giri finecorsa Limit switch rotation	0 ÷ 28
Consumo a riposo (solo per motori RADIO) Stand-by consumption (only for RADIO motors)	< 0,5 W
Marcatura Marking	CE



V4

V6 / VM6

V7 / VM7

TABELLA DELLE PORTATE - AVVOLGIBILI (Kg) - ROLLING SHUTTER CAPACITY (Kg)

Rullo Tube	Spessore telo Slat thickness	Altezza tapparella Rolling shutter height															
			V4-6/24	V4-9/17	V6-8/17 VM6-8/17	V6-12/17 VM6-12/17	V6-15/13 VM6-15/13	V6-22/17 VM6-22/17	V6-27/13 VM6-27/13	V6-28/17 VM6-28/17	V6-35/13 VM6-35/13	V6-38/17 VM6-38/17	V6-45/13 VM6-45/13	V7-80/12 VM7-80/12	V7-100/12 VM7-100/12	V7-130/9 VM7-130/9	
Ø (mm)	mm	H (m)	6 Nm	9 Nm	8 Nm	12 Nm	15 Nm	22 Nm	27 Nm	28 Nm	35 Nm	38 Nm	45 Nm	80 Nm	100 Nm	130 Nm	
40	9	1,5	15	20	-	-	-	-	-	-	-	-	-	-	-	-	
		2,4	13	18	-	-	-	-	-	-	-	-	-	-	-	-	-
		3,0	11	16	-	-	-	-	-	-	-	-	-	-	-	-	-
60	9	1,5	-	-	16	24	31	45	55	57	71	77	-	-	-	-	
		2,4	-	-	15	22	28	41	50	52	65	70	83	-	-	-	-
		3,0	-	-	13	19	24	35	42	44	55	60	71	-	-	-	-
60	14	1,5	-	-	15	22	28	41	50	52	65	70	83	-	-	-	
		2,4	-	-	13	19	24	35	42	44	55	60	71	-	-	-	
		3,0	-	-	11	16	20	30	37	38	48	52	61	-	-	-	
70	14	1,5	-	-	13	20	25	36	44	46	58	62	74	132	164	-	
		2,4	-	-	12	17	22	32	39	41	51	55	66	116	146	189	
		3,0	-	-	10	15	19	28	34	36	45	48	57	102	127	166	
102	19	2,4	-	-	-	-	-	-	-	-	-	-	-	82	102	133	
		3,0	-	-	-	-	-	-	-	-	-	-	-	78	97	126	
		4,0	-	-	-	-	-	-	-	-	-	-	-	72	90	117	

PORTATE INDICATIVE

- Per avvolgibili in acciaio o alluminio estruso considerare la portata ridotta del 30%
- Ogni installatore deve testare il prodotto in relazione alla propria situazione, poichè la portata potrebbe essere notevolmente ridotta in funzione di vari fattori (es.: attrito, tipo di tapparella, condizioni di installazione, diametro di avvolgimento, ecc.)

INDICATION OF CAPACITY

- The capacity for steel or extruded aluminium rolling shutters has to be reduced by 30%.
- Any installer has to test the product in relation to the current situation as the capacity could be considerably reduced depending on various elements (i.e. friction, type of rolling shutters, installation conditions, etc.)

PORTATE TENDE DA SOLE - AWNINGS CAPACITY

Sporgenza bracci Lever arms length	Numero bracci Number of lever arms			
	2	4	6	8
1,75	V6-27/13 - V6-28/17 VM6-27/13 - VM6-28/17	V6-35/13 - V6-38/17 VM6-35/13 - VM6-38/17	V6-45/13 VM6-45/13	V7-80/12 VM7-80/12
2,50	V6-35/13 - V6-38/17 VM6-35/13 - VM6-38/17	V6-45/13 VM6-45/13	V7-80/12 VM7-80/12	V7-80/12 VM7-80/12
3,00	V6-35/13 - V6-38/17 VM6-35/13 - VM6-38/17	V6-45/13 VM6-45/13	V7-80/12 VM7-80/12	V7-100/12 VM7-100/12
3,50	V6-45/13 VM6-45/13	V7-80/12 VM7-80/12	V7-100/12 VM7-100/12	V7-100/12 VM7-100/12
4,00	V7-80/12 VM7-80/12	V7-100/12 VM7-100/12	V7-100/12 VM7-100/12	V7-130/9 VM7-130/9
4,50	V7-100/12 VM7-100/12	V7-130/9 VM7-130/9	V7-130/9 VM7-130/9	V7-130/9 VM7-130/9

PORTATE INDICATIVE

- Ogni installatore deve testare il prodotto in relazione alla propria situazione poichè la portata potrebbe essere notevolmente ridotta in funzione di vari fattori (es.: forza dei bracci, diametro del rullo, condizioni di installazione, ecc.)

INDICATION OF CAPACITY

- Any installer has to test the product in relation to the current situation as the capacity could be considerably reduced depending on various elements (i.e. strength of lever arms, tube diameter, installation conditions, etc.)







V4

Articolo Item	Modello Model	Coppia Torque	Velocità Speed	Peso avvolgibile* Rolling shutter weight*		Potenza assorbita Absorbed power	Corrente assorbita Current consumption	Misura Dimension
				H=1,5m kg	H=2,4m kg			
		Nm	gir/min. rpm			W	A	C (mm)
555.M.S1.00	V4-6/24	6	24	15	13	125	0,55	498
555.M.V1.00	V4-9/17	9	17	20	18	125	0,55	498

* Portate indicative: vedi tabella pag. 10 per dettagli - * Indication of capacity: see table pag. 10 for details

Con un diametro di avvolgimento maggiore di Ø40 le portate diminuiscono - With a winding diameter larger than Ø40 the load capacity is reduced

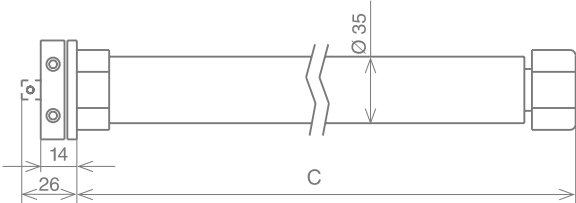
Automatismi compatibili - Compatible controls	Dimensioni - Dimensions
 <p>596REU00</p> <p>+</p>  <p>595TX100</p>  <p>596TX..</p>  <p>595MX100</p>  <p>595PX..</p>	

MOTORIDUTTORI CON FINECORSA REGOLABILE A VITE
MOTORS WITH ADJUSTABLE SCREW END STROKE

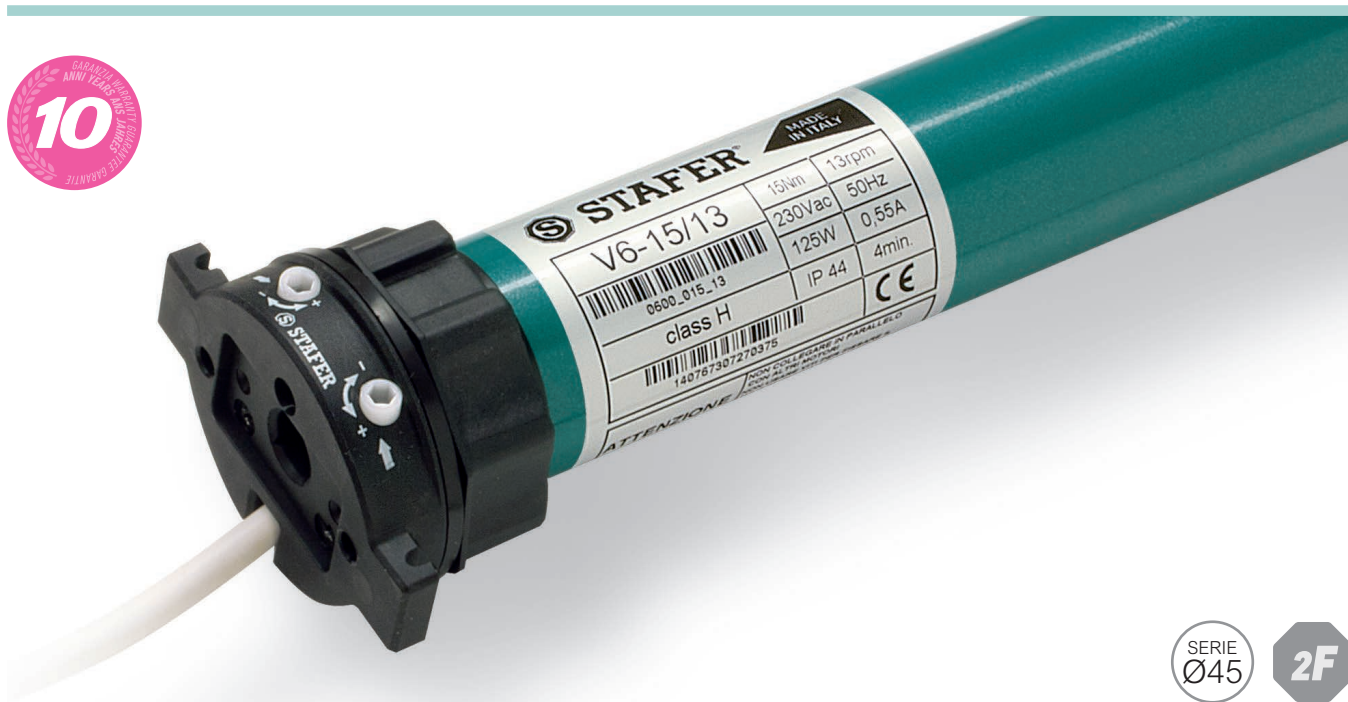

V6

Articolo Item	Modello Model	Coppia Torque	Velocità Speed	Peso avvolgibile* Rolling shutter weight*		Potenza assorbita Absorbed power	Corrente assorbita Current consumption	Misura Dimension
				H=1,5m kg	H=2,4m kg			
		Nm	gir/min. rpm			W	A	C (mm)
560.M.N1.00	V6-15/13	15	13	28	24	125	0,55	473
560.M.N2.00	V6-27/13	27	13	50	42	190	0,85	533
560.M.N3.00	V6-35/13	35	13	65	55	230	1,05	583
560.M.N4.00	V6-45/13	45	13	83	71	290	1,30	583
560.M.V0.00	V6-8/17	8	17	15	13	105	0,50	473
560.M.V1.00	V6-12/17	12	17	22	19	125	0,55	473
560.M.V2.00	V6-22/17	22	17	41	35	190	0,85	533
560.M.V3.00	V6-28/17	28	17	52	44	230	1,05	583
560.M.V4.00	V6-38/17	38	17	70	60	290	1,30	583

* Portate indicative: vedi tabella pag. 10 per dettagli - * Indication of capacity: see table pag. 10 for details

Con un diametro di avvolgimento maggiore di Ø60 le portate diminuiscono - With a winding diameter larger than Ø60 the load capacity is reduced

Automatismi compatibili - Compatible controls		Dimensioni - Dimensions	
<p>596REU00</p>			
<p>595TX100 596TX.. 595MX100 595PX..</p>		<p>Su richiesta i motoriduttori possono essere forniti con tensioni e frequenze diverse</p> <p>On request electrical motors can be supplied with different voltages and frequencies</p>	

MOTORIDUTTORI CON FINECORSA REGOLABILE A VITE E TESTA RINFORZATA
MOTORS WITH ADJUSTABLE SCREW END STROKE AND REINFORCED HEAD

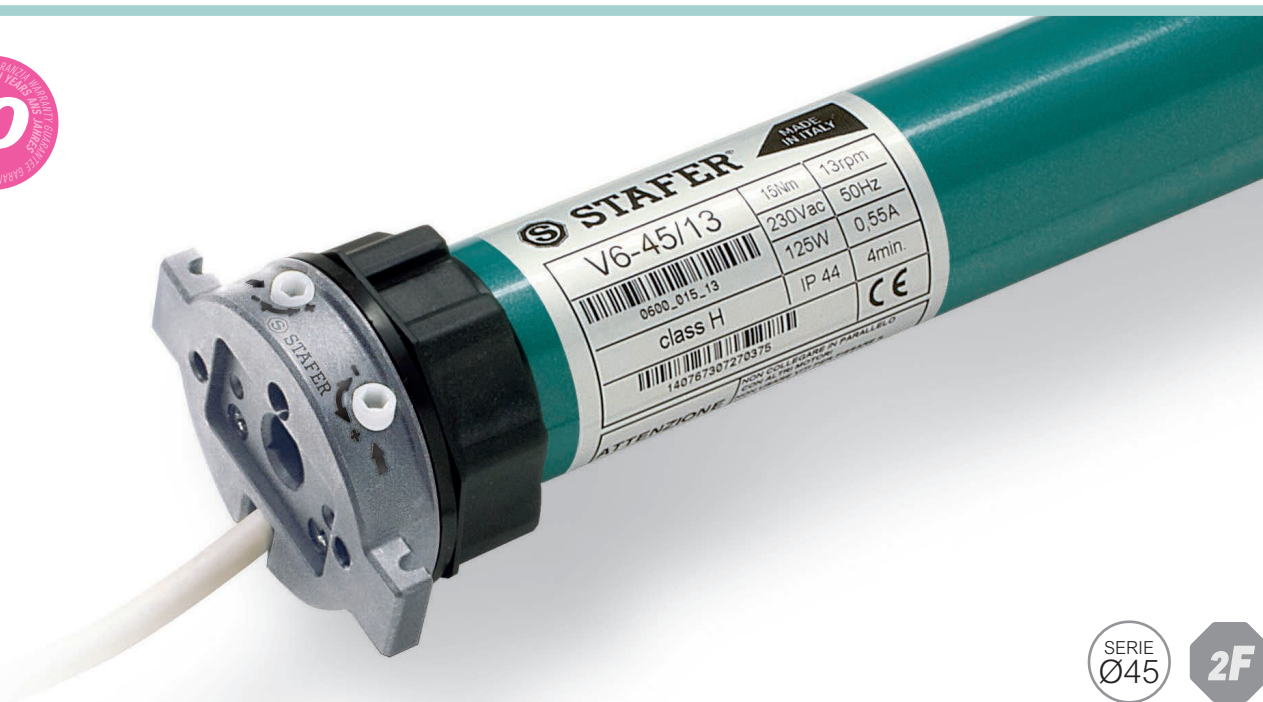

V6 STRONG

Articolo Item	Modello Model	Coppia Torque	Velocità Speed	Peso avvolgibile* Rolling shutter weight*		Potenza assorbita Absorbed power	Corrente assorbita Current consumption	Misura Dimension
				H=1,5m kg	H=2,4m kg			
		Nm	gir/min. rpm			W	A	C (mm)
560.M.Z4.00	V6-45/13	45	13	83	71	290	1,30	583

* Portate indicative: vedi tabella pag. 10 per dettagli – * Indication of capacity: see table pag. 10 for details

Con un diametro di avvolgimento maggiore di Ø60 le portate diminuiscono - With a winding diameter larger than Ø60 the load capacity is reduced

Automatismi compatibili - Compatible controls				Dimensioni - Dimensions	
<p>596REU00</p>					
<p>595TX100 596TX.. 595MX100 595PX..</p>					
<p>Su richiesta i motoriduttori possono essere forniti con tensioni e frequenze diverse</p>				<p>On request electrical motors can be supplied with different voltages and frequencies</p>	

MOTORIDUTTORI CON FINECORSA REGOLABILE A VITE E CONDENSATORE ESTERNO
MOTORS WITH ADJUSTABLE SCREW END STROKE AND EXTERNAL CAPACITOR

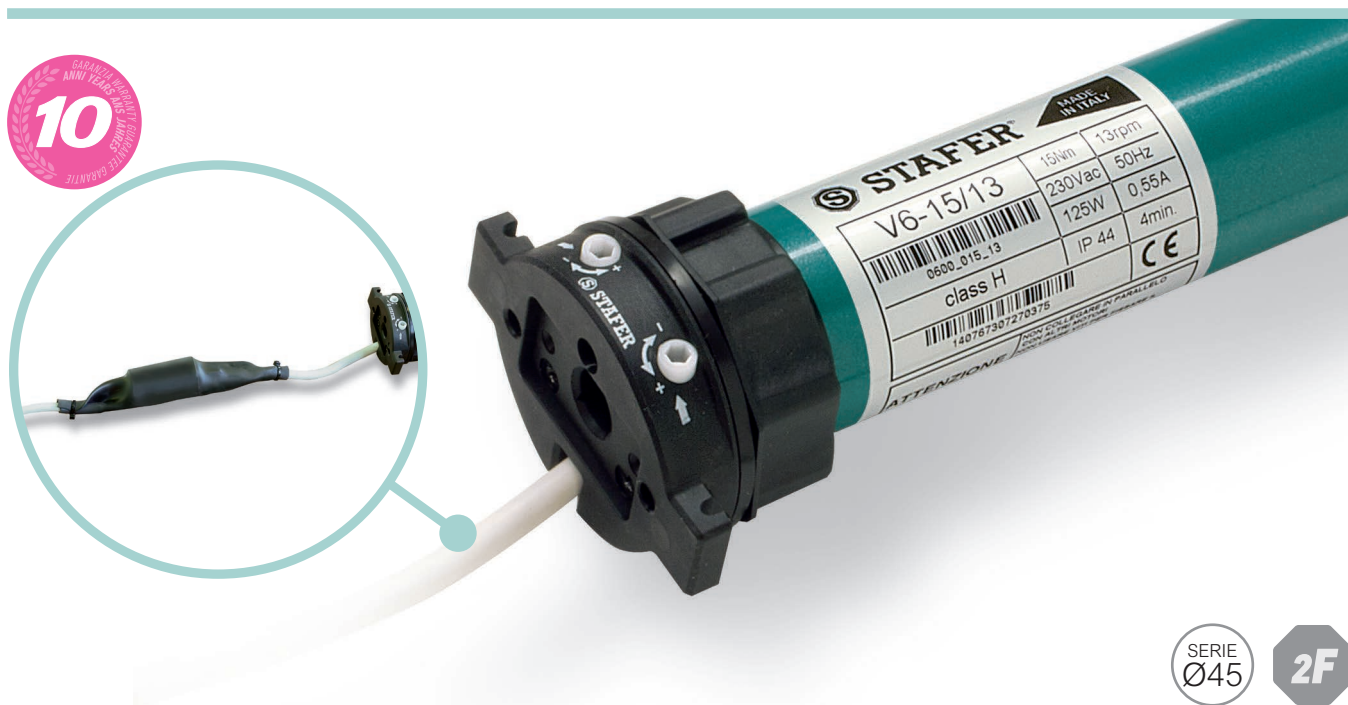





V6 SHORT

Articolo Item	Modello Model	Coppia Torque	Velocità Speed	Peso avvolgibile* Rolling shutter weight*		Potenza assorbita Absorbed power	Corrente assorbita Current consumption	Misura Dimension
				H=1,5m kg	H=2,4m kg			
		Nm	gir/min. rpm			W	A	C (mm)
560.C.N1.00	V6-15/13	15	13	28	24	125	0,55	423
560.C.N2.00	V6-27/13	27	13	50	42	190	0,85	483
560.C.N4.00	V6-45/13	45	13	83	71	290	1,30	483
560.C.V0.00	V6-8/17	8	17	15	13	105	0,50	423
560.C.V1.00	V6-22/17	22	17	41	35	190	0,85	483

* Portate indicative: vedi tabella pag. 10 per dettagli – * Indication of capacity: see table pag. 10 for details

Con un diametro di avvolgimento maggiore di Ø60 le portate diminuiscono - With a winding diameter larger than Ø60 the load capacity is reduced

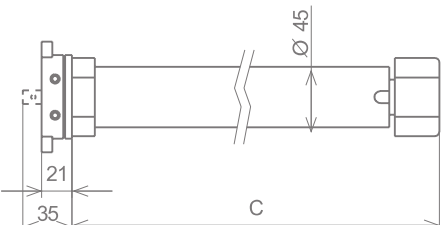
Automatismi compatibili - Compatible controls	Dimensioni - Dimensions
 <p>596REU00</p> <p>+</p>  <p>595TX100</p>  <p>596TX..</p>  <p>595MX100</p>  <p>595PX..</p>	 <p>Su richiesta i motoriduttori possono essere forniti con tensioni e frequenze diverse</p> <p>On request electrical motors can be supplied with different voltages and frequencies</p>

MOTORIDUTTORI CON FINECORSA REGOLABILE A VITE ED INNESTO RAPIDO
MOTORS WITH ADJUSTABLE SCREW END STROKE AND POWER CONNECTOR



V6 INNESTO RAPIDO | POWER CONNECTOR

Articolo Item	Modello Model	Coppia Torque	Velocità Speed	Peso avvolgibile* Rolling shutter weight*		Potenza assorbita Absorbed power	Corrente assorbita Current consumption	Misura Dimension
				H=1,5m kg	H=2,4m kg			
		Nm	girilmin. rpm			W	A	C (mm)
560.M.E1.00	V6-15/13	15	13	28	24	125	0,55	473
560.M.E2.00	V6-27/13	27	13	50	42	190	0,85	533
560.M.E3.00	V6-35/13	35	13	65	55	230	1,05	583
560.M.E4.00	V6-45/13	45	13	83	71	290	1,30	583

* Portate indicative: vedi tabella pag. 10 per dettagli – * Indication of capacity: see table pag. 10 for details

Con un diametro di avvolgimento maggiore di Ø60 le portate diminuiscono - With a winding diameter larger than Ø60 the load capacity is reduced

Automatismi compatibili - Compatible controls		+	Dimensioni - Dimensions	
<p>596REU00</p>				
<p>595TX100</p>	<p>596TX..</p>		<p>Su richiesta i motoriduttori possono essere forniti con tensioni e frequenze diverse</p> <p>On request electrical motors can be supplied with different voltages and frequencies</p>	
<p>595MX100</p>	<p>595PX..</p>			

MOTORIDUTTORI CON COMANDO A MANO DI EMERGENZA E FINECORSA REGOLABILE A VITE
MOTORS WITH MANUAL OVERRIDE AND ADJUSTABLE SCREW END STROKE



Finecorsa regolabile a vite da entrambi i lati
Adjustable screw end stroke on both sides



VM6

Articolo Item	Modello Model	Coppia Torque	Velocità Speed	Peso avvolgibile* Rolling shutter weight*		Potenza assorbita Absorbed power	Corrente assorbita Current consumption	Misura Dimension
				H=1,5m kg	H=2,4m kg			
		Nm	gir/min. rpm			W	A	C (mm)
561.M.N1.00	VM6-15/13	15	13	28	24	125	0,55	583/533**
561.M.N2.00	VM6-27/13	27	13	50	42	190	0,85	583
561.M.N3.00	VM6-35/13	35	13	65	55	230	1,05	633
561.M.N4.00	VM6-45/13	45	13	83	71	290	1,30	633
561.M.V0.00	VM6-8/17	8	17	15	13	105	0,50	583/533**
561.M.V1.00	VM6-12/17	12	17	22	19	125	0,55	583/533**
561.M.V2.00	VM6-22/17	22	17	41	35	190	0,85	583
561.M.V3.00	VM6-28/17	28	17	52	44	230	1,05	633
561.M.V4.00	VM6-38/17	38	17	70	60	290	1,30	633

* Portate indicative: vedi tabella pag. 10 per dettagli - * Indication of capacity: see table pag. 10 for details

** Su richiesta fornibile in versione accorciata C=533 mm con condensatore esterno

** On request it can be supplied in a shortened version (C=533 mm) with an external capacitor

Con un diametro di avvolgimento maggiore di Ø60 le portate diminuiscono - With a winding diameter larger than Ø60 the load capacity is reduced

Automatismi compatibili - Compatible controls			Dimensioni - Dimensions	
<p>596REU00</p>	+	<p>Asta Hand crank pag. 186</p>		
<p>595TX100 596TX.. 595MX100 595PX..</p>		<p>Snodo Joint pag. 185</p>		
			<p>Rapporto manovra di soccorso - Manual override ratio 1:54</p>	
			<p>Su richiesta i motoriduttori possono essere forniti con tensioni e frequenze diverse</p>	
			<p>On request electrical motors can be supplied with different voltages and frequencies</p>	



V6 s

Articolo Item	Modello Model	Coppia Torque	Velocità Speed	Peso avvolgibile* Rolling shutter weight*		Potenza assorbita Absorbed power	Corrente assorbita Current consumption	Misura Dimension
				H=1,5m kg	H=2,4m kg			
		Nm	gir/min. rpm			W	A	C (mm)
567.M.N2.00	V6.S-27/13	27	13	50	42	190	0,85	533
567.M.N3.00	V6.S-35/13	35	13	65	55	230	1,05	583
567.M.N4.00	V6.S-45/13	45	13	83	71	290	1,30	583

* Portate indicative: vedi tabella pag. 10 per dettagli – * Indication of capacity: see table pag. 10 for details

Con un diametro di avvolgimento maggiore di Ø60 le portate diminuiscono - With a winding diameter larger than Ø60 the load capacity is reduced

Tutti gli articoli compatibili con questo tipo di motore sono consultabili all'interno del catalogo "SISTEMA SERRANDA" che trovi nell'area Download su www.stafer.com

All items compatible with this type of motor are available in the "ROLLING SHUTTER DOOR SYSTEM" catalogue that you can find in the download area on www.stafer.com

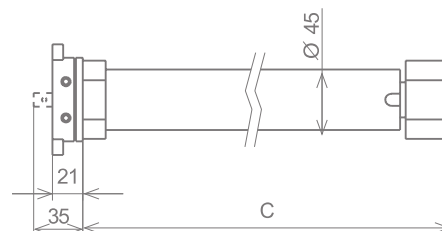

Su richiesta i motoriduttori possono essere forniti con tensioni e frequenze diverse

On request electrical motors can be supplied with different voltages and frequencies

MOTORIDUTTORI CON RADIO RICEVENTE INCORPORATA (433,42 MHz)
MOTORS WITH BUILT-IN RADIO RECEIVER (433,42 MHz)



V6 RX.3

Articolo Item	Modello Model	Coppia Torque	Velocità Speed	Peso avvolgibile* Rolling shutter weight*		Potenza assorbita Absorbed power	Corrente assorbita Current consumption	Misura Dimension
				H=1,5m kg	H=2,4m kg			
		Nm	gir/min. rpm			W	A	C (mm)
525.M.N1.00	V6.RX.3 -15/13	15	13	28	24	125	0,55	633
525.M.N2.00	V6.RX.3 -27/13	27	13	50	42	190	0,85	673
525.M.N3.00	V6.RX.3 -35/13	35	13	65	55	230	1,05	723
525.M.N4.00	V6.RX.3 -45/13	45	13	83	71	290	1,30	723
525.M.V0.00	V6.RX.3 -8/17	8	17	15	13	105	0,50	633
525.M.V1.00	V6.RX.3 -12/17	12	17	22	19	125	0,55	633
525.M.V2.00	V6.RX.3 -22/17	22	17	41	35	190	0,85	673
525.M.V3.00	V6.RX.3 -28/17	28	17	52	44	230	1,05	723
525.M.V4.00	V6.RX.3 -38/17	38	17	70	60	290	1,30	723

* Portate indicative: vedi tabella pag. 10 per dettagli - * Indication of capacity: see table pag. 10 for details

Con un diametro di avvolgimento maggiore di Ø60 le portate diminuiscono - With a winding diameter larger than Ø60 the load capacity is reduced

Automatismi compatibili - Compatible controls	Dimensioni - Dimensions
<p>595KXS00</p> <p>595MX100</p> <p>595TX100</p> <p>596TX..</p> <p>595PX..</p>	<p>21 35 Ø45 C</p>
<p>Su richiesta i motoriduttori possono essere forniti con tensioni e frequenze diverse</p>	<p>On request electrical motors can be supplied with different voltages and frequencies</p>

MOTORIDUTTORI CON RADIO RICEVENTE INCORPORATA (433,42 MHZ) ED INNESTO RAPIDO
MOTORS WITH BUILT-IN RADIO RECEIVER (433,42 MHz) AND POWER CONNECTOR

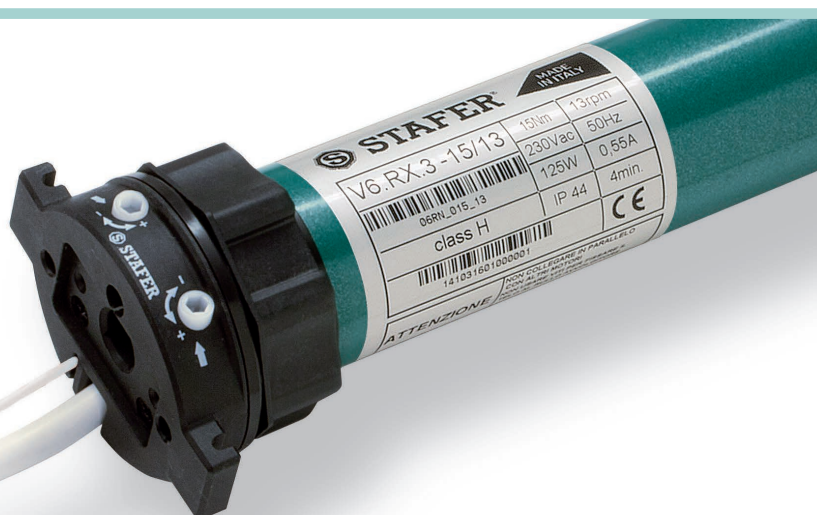

V6 RX.3 INNESTO RAPIDO | POWER CONNECTOR

Articolo Item	Modello Model	Coppia Torque	Velocità Speed	Peso avvolgibile* Rolling shutter weight*		Potenza assorbita Absorbed power	Corrente assorbita Current consumption	Misura Dimension
				H=1,5m kg	H=2,4m kg			
		Nm	gir/min. rpm			W	A	C (mm)
525.M.E1.00	V6.RX.3 -15/13	15	13	28	24	125	0,55	633
525.M.E2.00	V6.RX.3 -27/13	27	13	50	42	190	0,85	673
525.M.E3.00	V6.RX.3 -35/13	35	13	65	55	230	1,05	723
525.M.E4.00	V6.RX.3 -45/13	45	13	83	71	290	1,30	723

* Portate indicative: vedi tabella pag. 10 per dettagli – * Indication of capacity: see table pag. 10 for details

Con un diametro di avvolgimento maggiore di Ø60 le portate diminuiscono - With a winding diameter larger than Ø60 the load capacity is reduced

Automatismi compatibili - Compatible controls	Dimensioni - Dimensions
<p>595KXS00</p> <p>595MX100</p> <p>595TX100</p> <p>596TX..</p> <p>595PX..</p>	<p>21 35 Ø45 C</p>
<p>Su richiesta i motoriduttori possono essere forniti con tensioni e frequenze diverse</p>	<p>On request electrical motors can be supplied with different voltages and frequencies</p>

MOTORIDUTTORI CON RADIO RICEVENTE INCORPORATA E COMANDO A MANO DI EMERGENZA (433,42 MHz)
MOTORS WITH BUILT-IN RADIO RECEIVER AND MANUAL OVERRIDE (433,42 MHz)



Finecorsa regolabile a vite da entrambi i lati
Adjustable screw end stroke on both sides



VM6 RX.3

Articolo Item	Modello Model	Coppia Torque	Velocità Speed	Peso avvolgibile* Rolling shutter weight*		Potenza assorbita Absorbed power	Corrente assorbita Current consumption	Misura Dimension
				H=1,5m kg	H=2,4m kg			
		Nm	gir/min. rpm			W	A	C (mm)
526.M.N1.00	VM6.RX.3 -15/13	15	13	28	24	125	0,55	673
526.M.N2.00	VM6.RX.3 -27/13	27	13	50	42	190	0,85	673
526.M.N3.00	VM6.RX.3 -35/13	35	13	65	55	230	1,05	723
526.M.N4.00	VM6.RX.3 -45/13	45	13	83	71	290	1,30	723
526.M.V0.00	VM6.RX.3 -8/17	8	17	15	13	105	0,50	673
526.M.V1.00	VM6.RX.3 -12/17	12	17	22	19	125	0,55	673
526.M.V2.00	VM6.RX.3 -22/17	22	17	41	35	190	0,85	673
526.M.V3.00	VM6.RX.3 -28/17	28	17	52	44	230	1,05	723
526.M.V4.00	VM6.RX.3 -38/17	38	17	70	60	290	1,30	723

* Portate indicative: vedi tabella pag. 10 per dettagli - * Indication of capacity: see table pag. 10 for details

Con un diametro di avvolgimento maggiore di Ø60 le portate diminuiscono - With a winding diameter larger than Ø60 the load capacity is reduced

Automatismi compatibili - Compatible controls				Dimensioni - Dimensions	
<p>596REU00</p>		+	<p>Asta Hand crank pag. 186</p>		
<p>595TX100 596TX.. 595MX100 595PX..</p>			<p>Snodo Joint pag. 185</p>		
				<p>Rapporto manovra di soccorso - Manual override ratio 1:54</p>	
				<p>Su richiesta i motoriduttori possono essere forniti con tensioni e frequenze diverse</p>	
				<p>On request electrical motors can be supplied with different voltages and frequencies</p>	

MOTORIDUTTORI CON FINE CORSA ELETTRONICO E RADIO RICEVENTE INCORPORATA (433,42 MHz)
MOTORS WITH ELECTRONIC LIMIT SWITCH AND BUILT-IN RADIO RECEIVER (433,42 MHz)

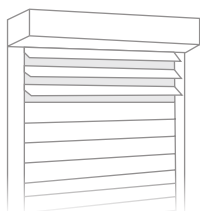

Con 3 finecorsa
With 3 limit switch



V6 RX.E3

Articolo Item	Modello Model	Coppia Torque	Velocità Speed	Peso avvolgibile* Rolling shutter weight*		Potenza assorbita Absorbed power	Corrente assorbita Current consumption	Misura Dimension
				H=1,5m kg	H=2,4m kg			
524.M.N1.00	V6.RX.E3 -15/13	15	13	28	24	125	0,55	533
524.M.N2.00	V6.RX.E3 -27/13	27	13	50	42	190	0,85	583
524.M.N3.00	V6.RX.E3 -35/13	35	13	65	55	230	1,05	633
524.M.N4.00	V6.RX.E3 -45/13	45	13	83	71	290	1,30	633
524.M.V0.00	V6.RX.E3 -8/17	8	17	15	13	105	0,50	533
524.M.V1.00	V6.RX.E3 -12/17	12	17	22	19	125	0,55	533
524.M.V2.00	V6.RX.E3 -22/17	22	17	41	35	190	0,85	583
524.M.V3.00	V6.RX.E3 -28/17	28	17	52	44	230	1,05	633
524.M.V4.00	V6.RX.E3 -38/17	38	17	70	60	290	1,30	633

* Portate indicative: vedi tabella pag. 10 per dettagli – * Indication of capacity: see table pag. 10 for details

Con un diametro di avvolgimento maggiore di Ø60 le portate diminuiscono - With a winding diameter larger than Ø60 the load capacity is reduced

Automatismi compatibili - Compatible controls	Dimensioni - Dimensions
<p>595KXS00</p> <p>595MX100</p> <p>595TX100</p> <p>596TX..</p> <p>595PX..</p>	<p>Su richiesta i motoriduttori possono essere forniti con tensioni e frequenze diverse</p> <p>On request electrical motors can be supplied with different voltages and frequencies</p>



STABER
V6-15/13

150mm	150mm
230V/50	50Hz
125W	0.55A
class H	IP 44
4min	

ATTENZIONE

CE



V7

Articolo Item	Modello Model	Coppia Torque	Velocità Speed	Ø70 Peso avvolgibile*		Ø102 Peso avvolgibile*		Potenza assorbita Absorbed power	Corrente assorbita Current consumption	Misura Dimension
				H=2,4m kg	H=3,0m kg	H=2,4m kg	H=3,0m kg			
		Nm	gir/min. rpm					W	A	C (mm)
570.M.N1.00	V7-80/12	80	12	116	102	82	78	375	1,70	640
570.M.N2.00	V7-100/12	100	12	146	127	102	97	410	1,85	640
570.M.N3.00	V7-130/9	130	9	189	166	133	126	410	1,85	640

* Portate indicative: vedi tabella pag. 10 per dettagli – * Indication of capacity: see table pag. 10 for details

Con un diametro di avvolgimento maggiore di Ø70 le portate diminuiscono - With a winding diameter larger than Ø70 the load capacity is reduced

Automatismi compatibili - Compatible controls				Dimensioni - Dimensions	
<p>596REU00</p>					
<p>595TX100 596TX.. 595MX100 595PX..</p>					
<p>Su richiesta i motoriduttori possono essere forniti con tensioni e frequenze diverse</p>				<p>On request electrical motors can be supplied with different voltages and frequencies</p>	

MOTORIDUTTORI CON COMANDO A MANO DI EMERGENZA E FINECORSA REGOLABILE A VITE
MOTORS WITH MANUAL OVERRIDE AND ADJUSTABLE SCREW END STROKE

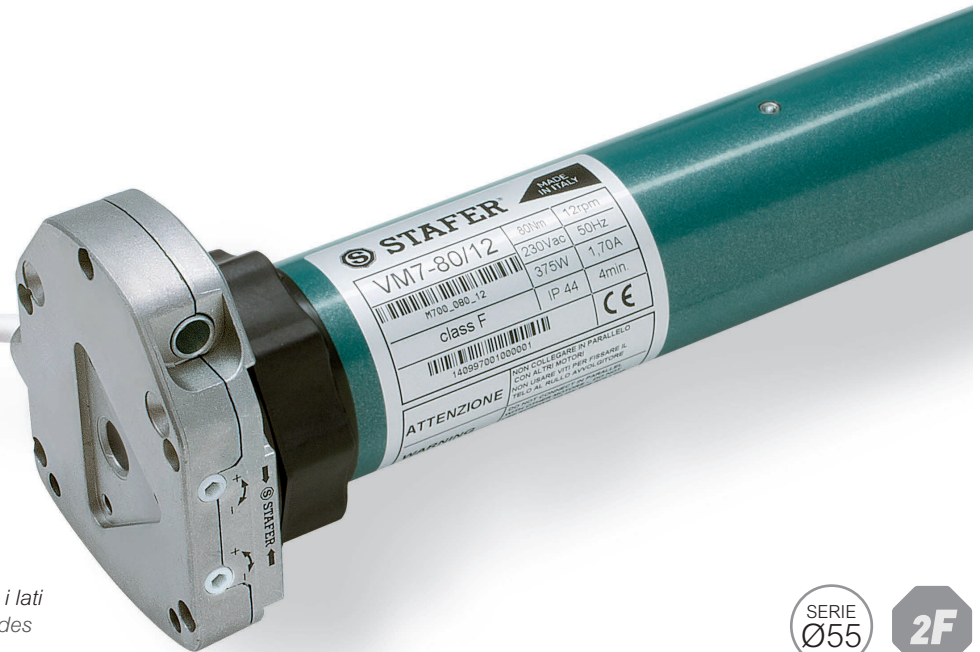
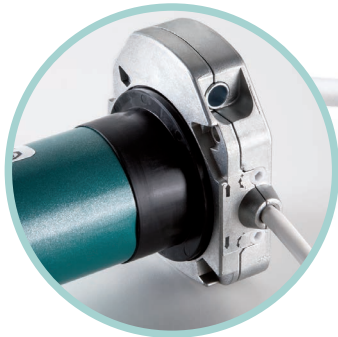

Finecorsa regolabile a vite da entrambi i lati
Adjustable screw end stroke on both sides

SERIE Ø55

2F

VM7

Articolo Item	Modello Model	Coppia Torque	Velocità Speed	Ø70 Peso avvolgibile*		Ø102 Peso avvolgibile*		Potenza assorbita Absorbed power	Corrente assorbita Current consumption	Misura Dimension
				H=2,4m kg	H=3,0m kg	H=2,4m kg	H=3,0m kg			
		Nm	girilmin. rpm					W	A	C (mm)
571.M.N1.00	VM7-80/12	80	12	116	102	82	78	375	1,70	690
571.M.N2.00	VM7-100/12	100	12	146	127	102	97	410	1,85	690
571.M.N3.00	VM7-130/9	130	9	189	166	133	126	410	1,85	690

* Portate indicative: vedi tabella pag. 10 per dettagli - * Indication of capacity: see table pag. 10 for details

Con un diametro di avvolgimento maggiore di Ø70 le portate diminuiscono - With a winding diameter larger than Ø70 the load capacity is reduced

Automatismi compatibili - Compatible controls				Dimensioni - Dimensions	
<p>596REU00</p>		+	<p>Asta Hand crank pag. 186</p>		
<p>595TX100 596TX.. 595MX100 595PX..</p>			<p>Snodo Joint pag. 185</p>		
				<p>Rapporto manovra di soccorso - Manual override ratio 1:54</p>	
				<p>Su richiesta i motoriduttori possono essere forniti con tensioni e frequenze diverse</p>	
				<p>On request electrical motors can be supplied with different voltages and frequencies</p>	



SERIE
Ø55

2F

V7 s

Articolo Item	Modello Model	Coppia Torque	Velocità Speed	Ø70 Peso avvolgibile*		Ø102 Peso avvolgibile*		Potenza assorbita Absorbed power	Corrente assorbita Current consumption	Misura Dimension
				H=2,4m kg	H=3,0m kg	H=2,4m kg	H=3,0m kg			
		Nm	gir/min. rpm					W	A	C (mm)
577.M.N1.00	V7.S-80/12	80	12	116	102	82	78	375	1,70	640
577.M.N2.00	V7.S-100/12	100	12	146	127	102	97	410	1,85	640
577.M.N3.00	V7.S-130/9	130	9	189	166	133	126	410	1,85	640

* Portate indicative: vedi tabella pag. 10 per dettagli – * Indication of capacity: see table pag. 10 for details

Con un diametro di avvolgimento maggiore di Ø70 le portate diminuiscono - With a winding diameter larger than Ø70 the load capacity is reduced

Tutti gli articoli compatibili con questo tipo di motore sono consultabili all'interno del catalogo "SISTEMA SERRANDA" che trovi nell'area Download su www.stafer.com

All items compatible with this type of motor are available in the "ROLLING SHUTTER DOOR SYSTEM" catalogue that you can find in the download area on www.stafer.com

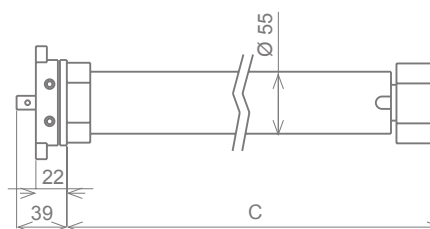

Su richiesta i motoriduttori possono essere forniti con tensioni e frequenze diverse

On request electrical motors can be supplied with different voltages and frequencies

MOTORIDUTTORI CON RADIO RICEVENTE INCORPORATA (433,42 MHz)
MOTORS WITH BUILT-IN RADIO RECEIVER (433,42 MHz)

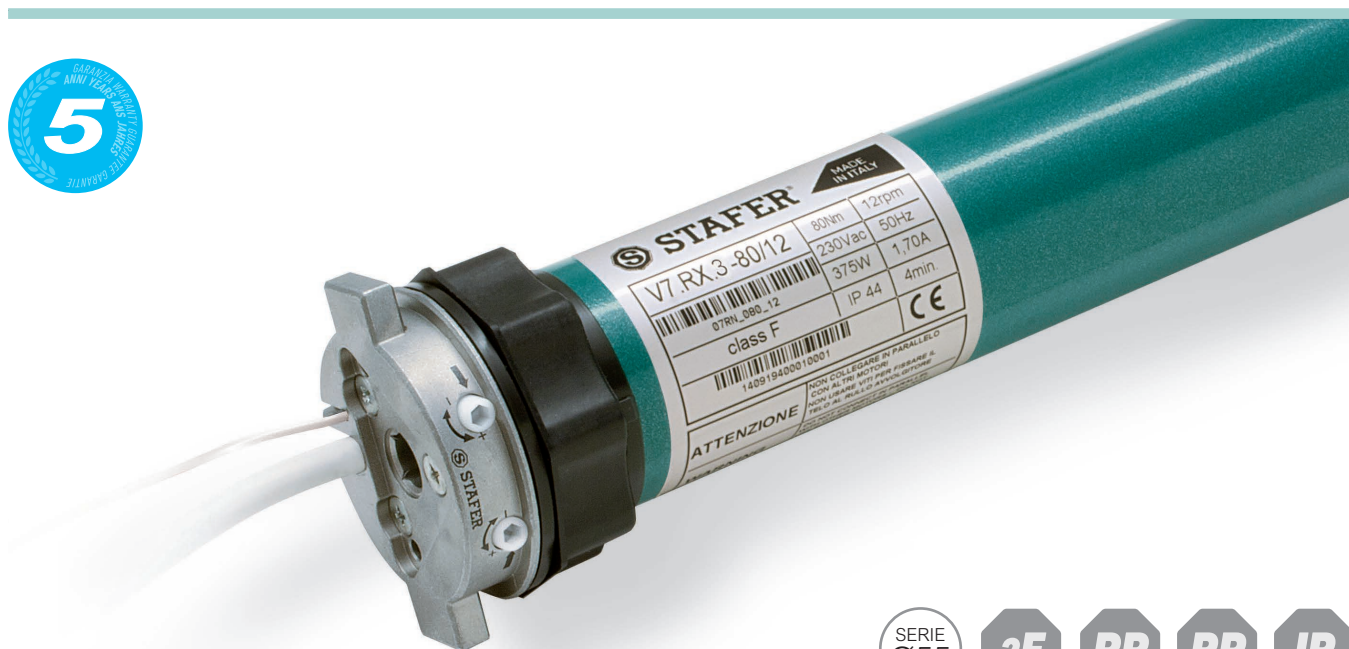

V7 RX.3

Articolo Item	Modello Model	Coppia Torque	Velocità Speed	Ø70 Peso avvolgibile*		Ø102 Peso avvolgibile*		Potenza assorbita Absorbed power	Corrente assorbita Current consumption	Misura Dimension
				Rolling shutter weight*	Rolling shutter weight*	Rolling shutter weight*	Rolling shutter weight*			
		Nm	girilmin. rpm	H=2,4m kg	H=3,0m kg	H=2,4m kg	H=3,0m kg	W	A	C (mm)
535.M.N1.00	V7.RX.3 -80/12	80	12	116	102	82	78	375	1,70	740
535.M.N2.00	V7.RX.3 -100/12	100	12	146	127	102	97	410	1,85	740
535.M.N3.00	V7.RX.3 -130/9	130	9	189	166	133	126	410	1,85	740

* Portate indicative: vedi tabella pag. 10 per dettagli – * Indication of capacity: see table pag. 10 for details

Con un diametro di avvolgimento maggiore di Ø70 le portate diminuiscono - With a winding diameter larger than Ø70 the load capacity is reduced

Automatismi compatibili - Compatible controls	Dimensioni - Dimensions
<p>595KXS00</p> <p>595MX100</p> <p>595TX100</p> <p>596TX..</p> <p>595PX..</p>	<p>22 39 Ø55 C</p>
	<p>Su richiesta i motoriduttori possono essere forniti con tensioni e frequenze diverse</p> <p>On request electrical motors can be supplied with different voltages and frequencies</p>

MOTORIDUTTORI CON FINE CORSA ELETTRONICO + RADIO RICEVENTE INCORPORATA (433,42 MHz)
MOTORS WITH ELECTRONIC LIMIT SWITCH AND BUILT-IN RADIO RECEIVER (433,42 MHz)

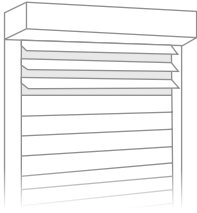

Con 3 finecorsa
With 3 limit switch



V7 RX.E3

Articolo Item	Modello Model	Coppia Torque	Velocità Speed	Ø70 Peso avvolgibile*		Ø102 Peso avvolgibile*		Potenza assorbita Absorbed power	Corrente assorbita Current consumption	Misura Dimension
				H=2,4m kg	H=3,0m kg	H=2,4m kg	H=3,0m kg			
		Nm	giri/min. rpm					W	A	C (mm)
534.M.N1.00	V7.RX.E3 -80/12	80	12	116	102	82	78	375	1,70	690
534.M.N2.00	V7.RX.E3 -100/12	100	12	146	127	102	97	410	1,85	690
534.M.N3.00	V7.RX.E3 -130/9	130	9	189	166	133	126	410	1,85	690

* Portate indicative: vedi tabella pag. 10 per dettagli – * Indication of capacity: see table pag. 10 for details

Con un diametro di avvolgimento maggiore di Ø70 le portate diminuiscono - With a winding diameter larger than Ø70 the load capacity is reduced

Automatismi compatibili - Compatible controls	Dimensioni - Dimensions
<p>595KXS00</p> <p>595MX100 595TX100 596TX.. 595PX..</p>	<p>22 39 Ø55 C</p>
<p>Su richiesta i motoriduttori possono essere forniti con tensioni e frequenze diverse</p>	<p>On request electrical motors can be supplied with different voltages and frequencies</p>

KIT ELETTORULLO TELESCOPICO PER AUTOMAZIONE TAPPARELLE "MERLINO" MOTORIZED TELESCOPIC TUBE "MERLINO" FOR ROLLING SHUTTERS

Articolo - Item		560.K.E1.00	560.K.E3.00
Limiti di utilizzo - Limits of use		KE1	KE3
Lunghezza totale rullo Lt (cm)* Overall tube length (cm)*	min.**	56	67
	max.	150	200
Spessore profilo tapparella S (mm) Slat thickness	min.	12	12
	max.	14	14

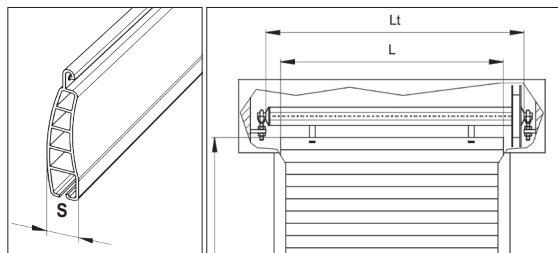

* LT = Distanza della battuta interna tra i due cuscinetti – * Gap between inner sides of ball bearings

** Misura minima ottenuta tagliando il rullo – ** Minimum length with cut steel tube



Componenti kit elettroscopico - Kit parts		KE1	KE3
Rif.to Ref.	Descrizione Description	Q.tà Q.ty	Q.tà Q.ty
1	Elettroscopico - Motorized tube	1	1
2	Prolunga - Tube extension	1	1
3	Calotta - Adjustable steel cap	1	1
4	Copiglia - Split pin	1	1
5	Vite autofilettante - Self-threading screw	1	1
6	Chiave regolazione fine corsa Adjusting key	1	1
7	Supporto elettroscopico fisso - Fixed bracket	1	1
8	Staffa supporto elettroscopico regolabile Adjustable bracket	1	1
9	Molla di aggancio - Security spring	3	5
10	Gancio di attacco - Slotted clip	3	5

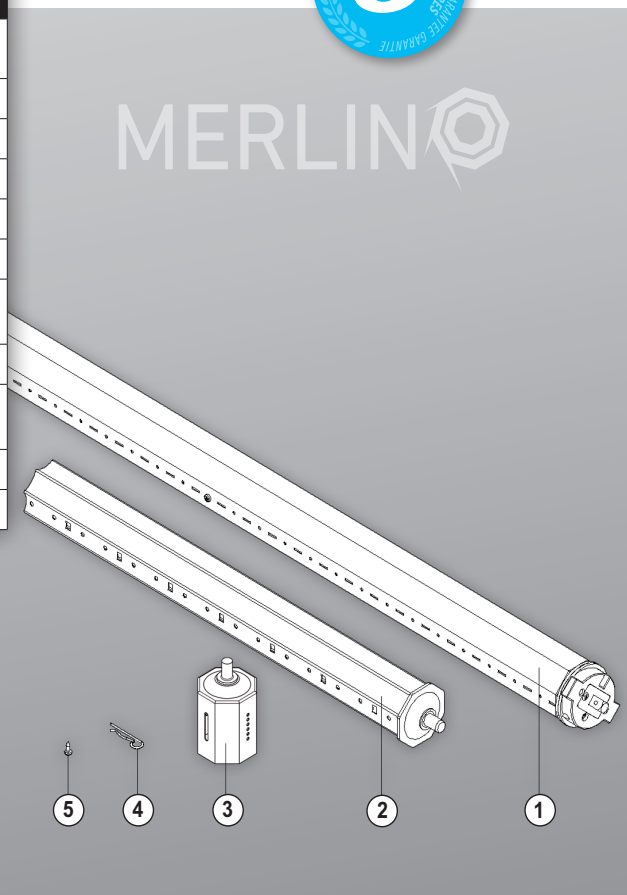

KIT ELETTRORULLO TELESCOPICO PER AUTOMAZIONE TAPPARELLE "MERLINO" MOTORIZED TELESCOPIC TUBE "MERLINO" FOR ROLLING SHUTTERS

SCelta DEL MODELLO MODEL CHOICE

Modello - Model	KE1				KE3	
Tapparelle in plastica / alluminio profilato - Plastic / Roll formed aluminium shutters						
Altezza tapparella Shutter height H (cm)	Larghezza tapparella - Shutter width L (cm)					
	< 75	75 - 100	100 - 125	125 - 150	150 - 175	175 - 200
< 125						
125 - 150						
150 - 175						
175 - 200						
200 - 225						
225 - 250						

Modello - Model	KE1				KE3	
Tapparelle in legno / acciaio / alluminio estruso - Wooden / steel / extruded aluminium shutters						
Altezza tapparella Shutter height H (cm)	Larghezza tapparella - Shutter width L (cm)					
	< 75	75 - 100	100 - 125	125 - 150	150 - 175	175 - 200
< 125						
125 - 150						
150 - 175						
175 - 200						
200 - 225						
225 - 250						

DATI TECNICI DEL MOTORE MOTOR DATA SHEET

Modello kit - Motorized tube model		560.K.E1.00	560.K.E3.00
		KE1	KE3
Motoriduttore - Motor		V6-15/13	V6-35/13
Coppia - Torque	Nm	15	35
Velocità - Speed	rpm	13	13
Alimentazione - Power supply	Vac / Hz	230 / 50	230 / 50
Potenza assorbita - Absorbed power	W	125	230
Assorbimento corrente - Current consumption	A	0,55	1,05
Tempo funzionamento continuo Continuous operating time	min	4	4
Grado di protezione - Protection degree		IP 44	IP 44
Classe di isolamento - Insulation class		H	H
Giri fine corsa - Limit switch rotation		0 ÷ 28	0 ÷ 28
Marcatura - Marking		CE	CE



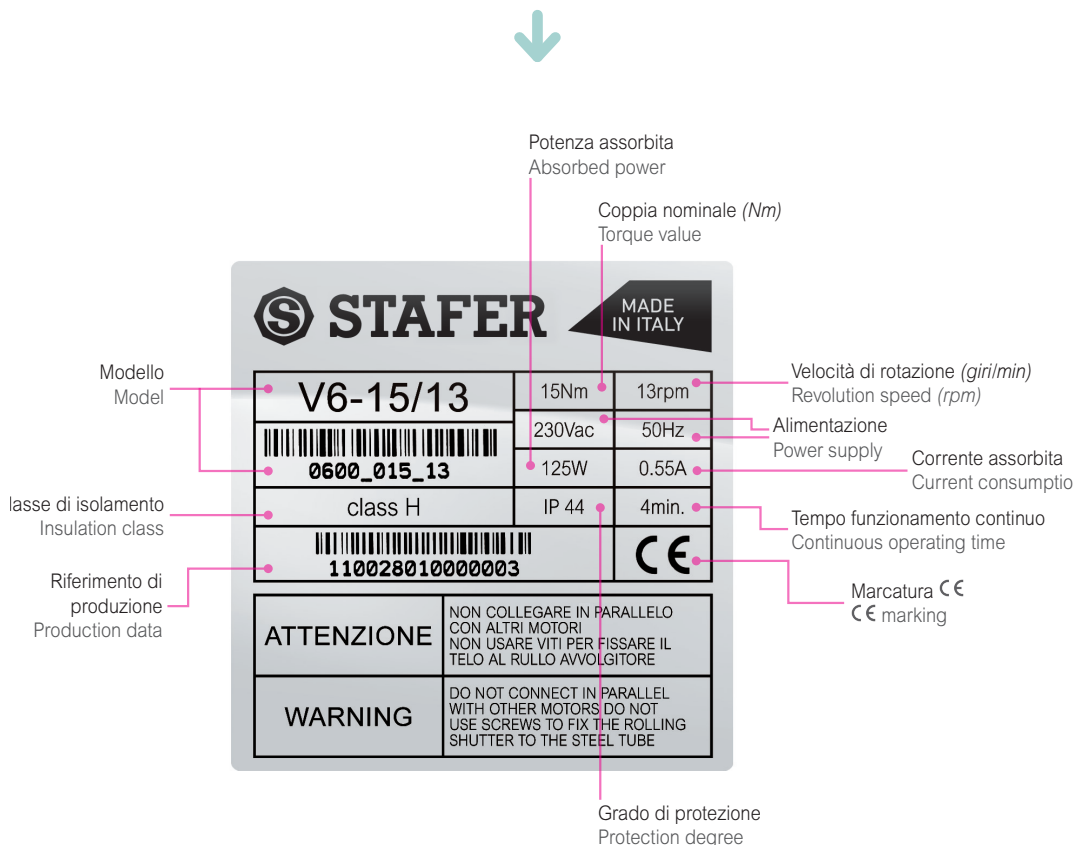

STAFER s.p.a. dichiara che gli articoli e le classi di prodotto presenti nella tabella di seguito riportata sono conformi ai requisiti essenziali ed alle disposizioni pertinenti, stabilite dalle direttive:
STAFER s.p.a. declares that the articles and the product classes in the table below are in compliance with the essential requirements and other relevant provisions established by the regulations:

Direttiva / Directive				
	Compatibilità Elettromagnetica Electromagnetic Compatibility	Bassa Tensione Low Voltage	Apparecchiature Radio Radio Equipment	Macchine Machinery
590MR100		X		
590MR400		X		
590S2M00	X	X		
591KSP00	X	X		
596CSR00	X	X		
596REU00	X	X	X	
596MUM00	X	X		
595TX100			X	
596TX100			X	
596TX500			X	
593PX193			X	
593MX100			X	
315K0000	X			
315KE000	X			
595KF200	X	X		
595KRS00	X	X	X	
595KXS00	X	X	X	
595KE100	X	X	X	
560KE100	X	X		X
560KE300	X	X		X

Direttiva / Directive				
	Compatibilità Elettromagnetica Electromagnetic Compatibility	Bassa Tensione Low Voltage	Apparecchiature Radio Radio Equipment	Macchine Machinery
CLASSE MOTORI V4 MOTOR CLASS V4	X	X		
CLASSE MOTORI V6 MOTOR CLASS V6	X	X		
CLASSE MOTORI VM6 MOTOR CLASS VM6	X	X		
CLASSE MOTORI V6S MOTOR CLASS V6S	X	X		
CLASSE MOTORI V7 MOTOR CLASS V7	X	X		
CLASSE MOTORI VM7 MOTOR CLASS VM7	X	X		
CLASSE MOTORI V7S MOTOR CLASS V7S	X	X		
CLASSE MOTORI V6RX3 MOTOR CLASS V6RX3	X	X	X	
CLASSE MOTORI VM6RX3 MOTOR CLASS VM6RX3	X	X	X	
CLASSE MOTORI V7RX3 MOTOR CLASS V7RX3	X	X	X	
CLASSE MOTORI V6RXE3 MOTOR CLASS V6RXE3	X	X	X	
CLASSE MOTORI V7RXE3 MOTOR CLASS V7RXE3	X	X	X	

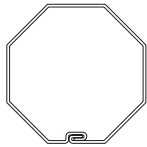
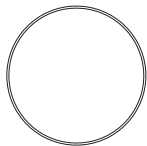
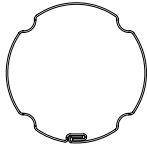
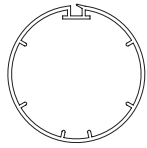

V4 SERIE Ø35

	Coppia adattatori per rullo ottagonale Octagonal tube set of adapters	
	<i>Articolo - Item</i>	<i>Per rullo Ø (mm) - For tube Ø (mm)</i>
	580.A.S6.90	40 - 6/10 (P-38)
	580.A.S8.90	40 - 8/10 (P-39)
	Coppia adattatori per rullo tondo liscio Set of adapters for round smooth tube	
	<i>Articolo - Item</i>	<i>Per rullo Ø (mm) - For tube Ø (mm)</i>
	580.A.T1.90	40 - 10/10 (P-37)
	580.A.T2.90	40 - 15/10 (P-36)
	580.A.T3.90	40 - 20/10 (P-35)
	Coppia adattatori per rullo tondo scanalato Z.F. Set of adapters for Z.F. tube	
	<i>Articolo - Item</i>	<i>Per rullo Ø (mm) - For tube Ø (mm)</i>
	580.A.Z4.90	45 (P-40)
	Coppia adattatori per rullo tondo con ogiva speciale Set of adapters for special round tube with ogive	
	<i>Articolo - Item</i>	<i>Per rullo Ø (mm) - For tube Ø (mm)</i>
	580.A.E1.90	44 (P-41)

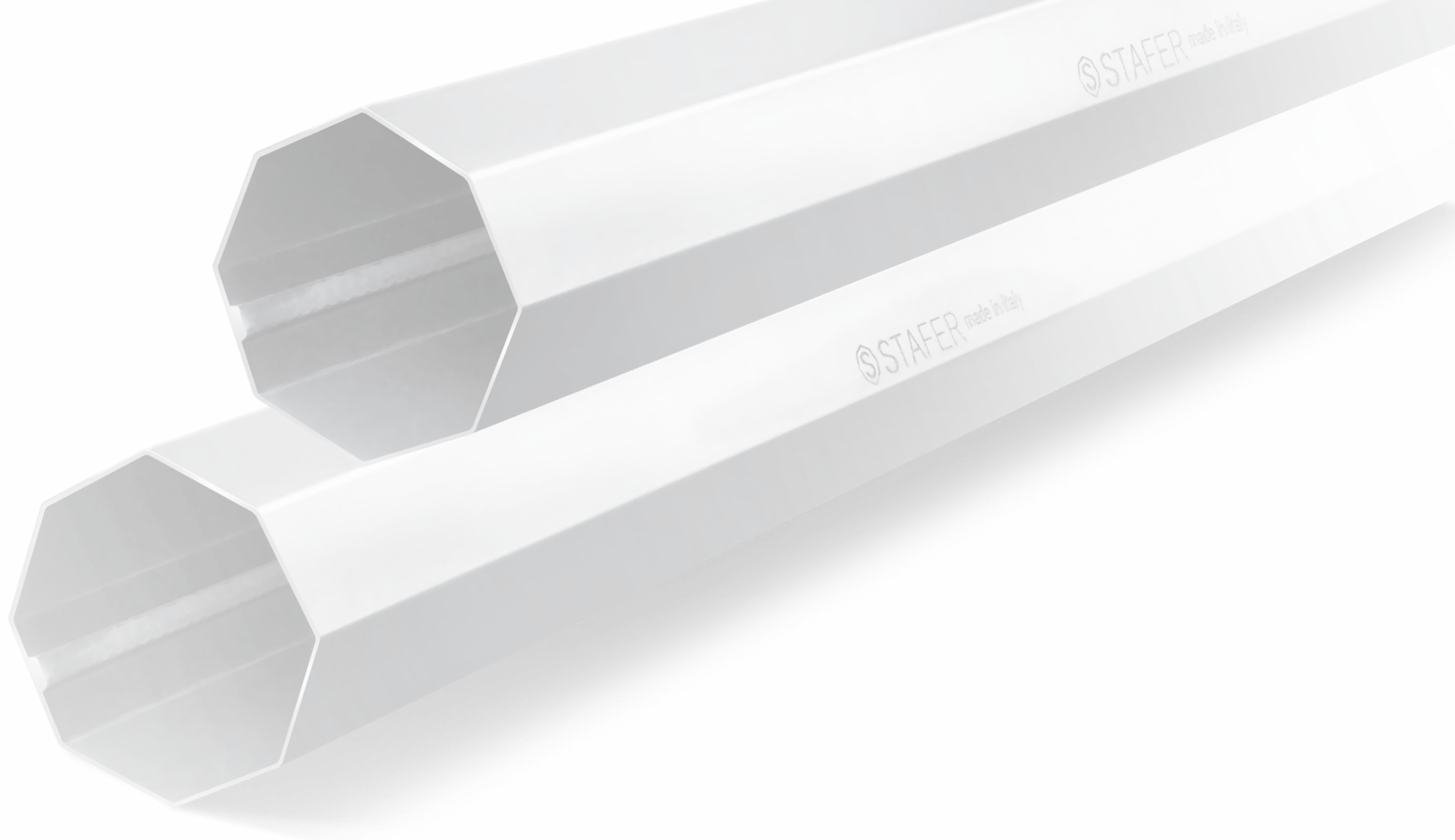

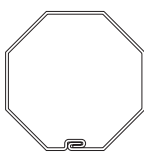

Le dimensioni si intendono riferite al diametro esterno del rullo
 The above mentioned dimensions refer to the outer diameter of the tube

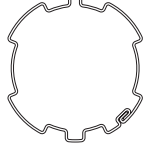
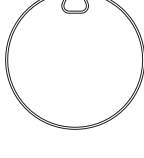
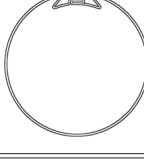
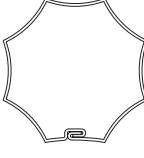
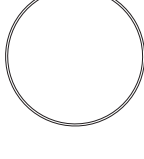
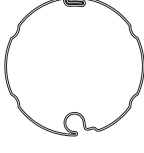

V6 -VM6 SERIE Ø45

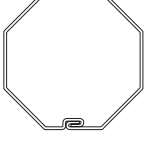
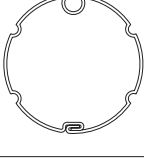
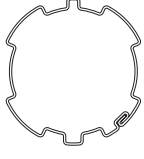
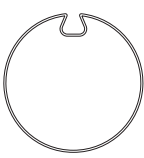
	Coppia adattatori per rullo ottagonale Octagonal tube set of adapters	
	<i>Articolo - Item</i>	<i>Per rullo Ø (mm) - For tube Ø (mm)</i>
	580.I.01.90	50 (P-19)
	580.C.R1.90	59 - 8/10 (P-24)
	580.C.01.90	60 - 10/10 (P-06)
	580.N.01.90	70 - 11/10 70 - 15/10 (P-12)
	Coppia adattatori per rullo tondo scanalato con ogiva Set of adapters for round grooved tube	
	<i>Articolo - Item</i>	<i>Per rullo Ø (mm) - For tube Ø (mm)</i>
	580.P.01.90	70 (P-21)
	580.S.01.90	78 (P-13)
	580.V.01.90	85 (P-23)
	Coppia adattatori per rullo tondo scanalato Z.F. Set of adapters for Z.F. tube	
	<i>Articolo - Item</i>	<i>Per rullo Ø (mm) - For tube Ø (mm)</i>
	580.F.01.90	54 (P-20)
	580.H.01.90	64 (P-18)
	580.U.01.90	80 (P-27)
	Coppia adattatori per rullo tondo con ogiva Set of adapters for round tube with ogive	
	<i>Articolo - Item</i>	<i>Per rullo Ø (mm) - For tube Ø (mm)</i>
	580.J.01.90	61 x 1,5 (P-17)
	580.G.01.90	62 (P-16)
	580.S.01.90	78 (P-13)
	Coppia adattatori per rullo tondo con ogiva larga Set of adapters for round tube with wide ogive	
	<i>Articolo - Item</i>	<i>Per rullo Ø (mm) - For tube Ø (mm)</i>
	580.Y.01.90	89 (P-25)
	Coppia adattatori per rullo ottagonale sagomato Set of adapters for octagonal shaped tube	
	<i>Articolo - Item</i>	<i>Per rullo Ø (mm) - For tube Ø (mm)</i>
	580.D.01.90	58 (P-11)
	Adattatore per rullo tondo liscio Round tube adapter	
	<i>Articolo - Item</i>	<i>Per rullo Ø (mm) - For tube Ø (mm)</i>
	580.B.01.90	50 - 15/10 (P-15R)
	580.E.01.90	60 - 15/10 (P-05)
	580.Q.01.90	70 - 15/10 (P-26)
	Coppia adattatori per rullo tondo BAT Set of adapters for BAT round tube	
	<i>Articolo - Item</i>	<i>Per rullo Ø (mm) - For tube Ø (mm)</i>
	580.L.01.90	70
	580.U.01.90	80 (P-27)

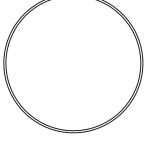
V7 -VM7 SERIE Ø55

	Coppia adattatori per rullo ottagonale Octagonal tube set of adapters	
	<i>Articolo - Item</i>	<i>Per rullo Ø (mm) - For tube Ø (mm)</i>
	580.N.05.70	70 - 11/10 70 - 15/10 (P-50)
	580.Z.10.70	102 - 20/10 (P-58)
	Coppia adattatori per rullo tondo scanalato con ogiva Set of adapters for round grooved tube	
	<i>Articolo - Item</i>	<i>Per rullo Ø (mm) - For tube Ø (mm)</i>
	580.V.05.70	85 (P-54)
	Coppia adattatori per rullo tondo scanalato Z.F. Set of adapters for Z.F. tube	
	<i>Articolo - Item</i>	<i>Per rullo Ø (mm) - For tube Ø (mm)</i>
	580.U.05.70	80 (P-55)
	Coppia adattatori per rullo tondo con ogiva Set of adapters for round tube with ogive	
	<i>Articolo - Item</i>	<i>Per rullo Ø (mm) - For tube Ø (mm)</i>
	580.S.05.70	78 (P-51)
	Coppia adattatori per rullo tondo con ogiva larga Set of adapters for round tube with wide ogive	
	<i>Articolo - Item</i>	<i>Per rullo Ø (mm) - For tube Ø (mm)</i>
	580.Y.05.70	89 (P-56)
	Adattatore per rullo tondo liscio Round tube adapter	
	<i>Articolo - Item</i>	<i>Per rullo Ø (mm) - For tube Ø (mm)</i>
	580.E.05.70	60 x 1,5 (P-53)
	Coppia adattatori per rullo tondo liscio Set of adapters for round tube	
	<i>Articolo - Item</i>	<i>Per rullo Ø (mm) - For tube Ø (mm)</i>
	580.Z.05.70	102 x 2 (P-52)
	580.W.05.70	100 x 2 (P-59)

Le misure si intendono riferite al diametro esterno del rullo
The above mentioned measures refer to the outer diameter of the tube

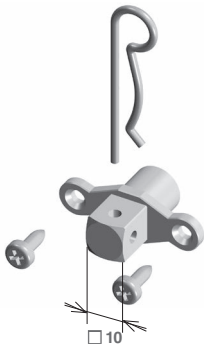

Inserto maschio quadro 10 mm zama Male insert - Square 10 mm - Zamak					
Articolo - Item	V4	V6	VM6	V7	VM7
581.M.00.70	•				

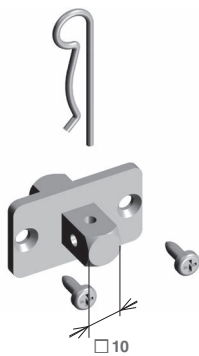

Inserto maschio quadro 10 mm - 2 Fori Male insert - Square 10 mm - 2 holes					
Articolo - Item	V4	V6	VM6	V7	VM7
581.N.20.20		•			
Inserto maschio quadro 10 mm - 2 Fori - Montato su motore Male insert - Square 10 mm - 2 holes - Assembled to motor					
Articolo - Item	V4	V6	VM6	V7	VM7
581.N.2M.20		•			

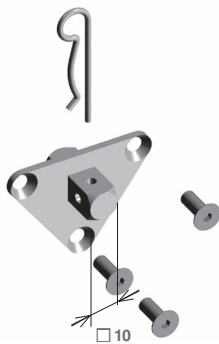

Inserto maschio quadro 10 mm - 3 Fori Male insert - Square 10 mm - 3 holes					
Articolo - Item	V4	V6	VM6	V7	VM7
581.N.30.20			•		
Inserto maschio quadro 10 mm - 3 Fori - Montato su motore Male insert - Square 10 mm - 3 holes - Assembled to motor					
Articolo - Item	V4	V6	VM6	V7	VM7
581.N.3M.20			•		

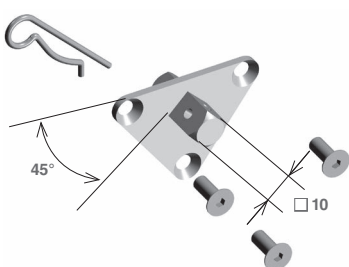

Inserto maschio quadro 10 mm a 45° - 3 Fori Male insert 45° - Square 10 mm - 3 holes					
Articolo - Item	V4	V6	VM6	V7	VM7
581.N.3Q.20			•		



Inserto maschio quadro 14 mm Male insert - Square 14 mm					
Articolo - Item	V4	V6	VM6	V7	VM7
581.N.34.20				•	•
Inserto maschio quadro 14 mm - 3 Fori - Montato su motore Male insert - Square 14 mm - 3 holes - Assembled to motor					
Articolo - Item	V4	V6	VM6	V7	VM7
581.N.4M.20				•	•

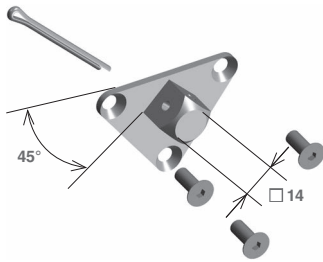

Inserto maschio quadro 14 mm a 45° Male insert 45° - Square 14 mm					
Articolo - Item	V4	V6	VM6	V7	VM7
581.N.Q4.20				•	•

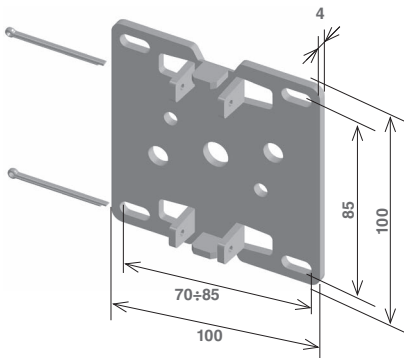

Supporto per fissaggio diretto - Direct anchoring support max 100 Nm					
Articolo - Item	V4	V6	VM6	V7	VM7
581.S.FD.20		•	•*	•	•**

Solo in abbinamento a: Use only with: 581R0070* - 581R0770**

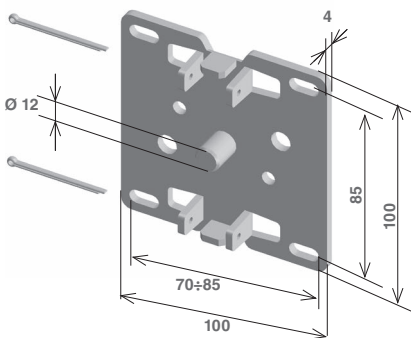

Supporto per fissaggio diretto con perno centrale Direct anchoring support with central pivot 130 Nm					
Articolo - Item	V4	V6	VM6	V7	VM7
581.S.PD.20				•	•**

Solo in abbinamento a: Use only with: 581R0770**

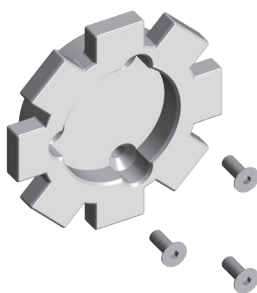

Inserto orientabile Serie 6 per art. 581SFD20 Revolving insert 6 Series for Item					
Articolo - Item	V4	V6	VM6	V7	VM7
581.R.00.70			•		

Inserto orientabile Serie 7 per art. 581SFD20 - 581SPD20 Revolving insert 7 Series for Item					
Articolo - Item	V4	V6	VM6	V7	VM7
581.R.07.70					•

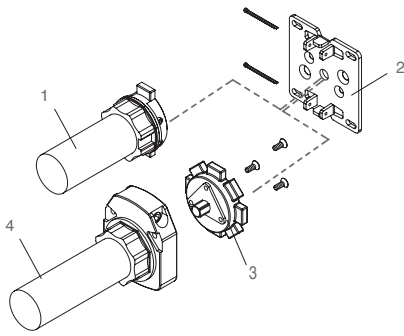

Esempio - Example

Fissaggio diretto serie Ø 45 mm Direct anchoring		
Articolo - Item	Descrizione - Description	Rif.
scegliere tipo - choose item	Motore Serie V6 - Motor V6 Series	1
581.S.FD.20	Supporto fissaggio diretto - Direct anchoring support	2
581.R.00.70	Inserto orientabile - Revolving insert	3
scegliere tipo - choose item	Motore Serie VM6 - Motor VM6 Series	4

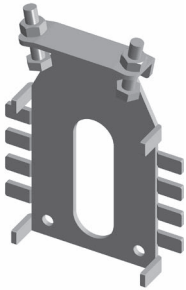

Per istruzioni di montaggio vedi cap.12
For installation instructions see chapter 12

Supporto per fianchi mini in alluminio 125÷205 mm Support for mini aluminium end caps					
Articolo - Item	V4	V6	VM6	V7	VM7
581.S.CM.20	•*	•		•	

Solo in abbinamento a: Use only with: 581MCM90*

Supporto per fianchi mini in alluminio 250 mm Support for mini aluminium end caps					
Articolo - Item	V4	V6	VM6	V7	VM7
581.S.LM.20		•		•	

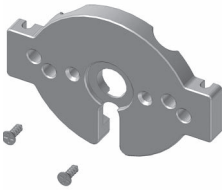

Supporto in plastica per fianchi in alluminio Plastic support for aluminium end caps					
Articolo - Item	V4	V6	VM6	V7	VM7
581.M.CM.90	•				

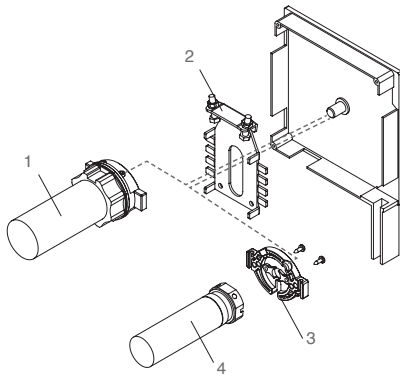

Esempio - Example

Fissaggio su fianchi mini in alluminio - Anchoring on aluminium end caps serie Ø 35 mm - Ø 45 mm		
Articolo - Item	Descrizione - Description	Rif.
scegliere tipo - choose item	Motore Serie V6 - Motor V6 Series	1
581.S.CM.20	Supporto - Support	2
581.M.CM.9	Supporto V4 - V4 Support	3
scegliere tipo - choose item	Motore Serie V4 - Motor V4 Series	4

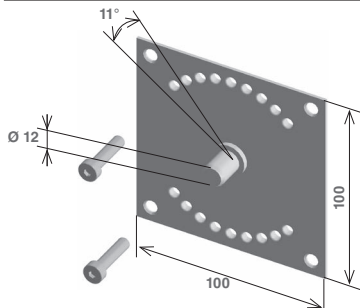

Supp. fissaggio diretto orientabile per fianchi standard Orienting support for midi end caps					
Articolo - Item	V4	V6	VM6	V7	VM7
581.S.PS.20			•		•

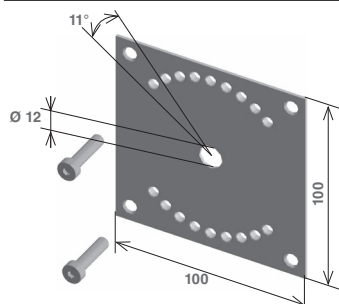

Supporto fissaggio diretto orientabile senza perno per fianchi mini Direct anchoring support without pivot for mini end caps					
Articolo - Item	V4	V6	VM6	V7	VM7
581.S.FM.20			•		•

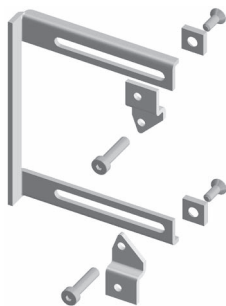

Kit staffe regolabili per minicassonetti alluminio
Adjustable brackets kit for mini aluminium end caps | 150-250 mm

Articolo - Item	V4	V6	VM6	V7	VM7
581.S.RE.20			•		•

Per istruzioni di montaggio vedi cap.12 - For installation instructions see chapter 12

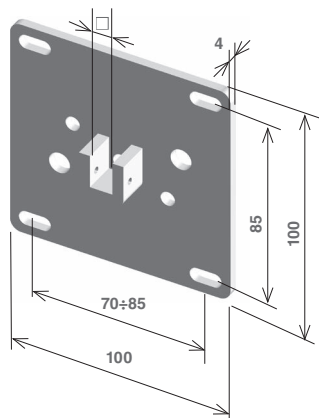

Supporto con sella quadro - Saddle plate square | □ 10 mm

Articolo - Item	V4	V6	VM6	V7	VM7
581.S.Q0.20	•	•	•		

Supporto con sella quadro - Saddle plate square | □ 14 mm

Articolo - Item	V4	V6	VM6	V7	VM7
581.S.Q4.20				•	•

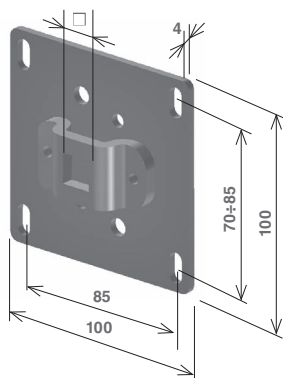

Supporto con foro quadro per fianchi maxi - Saddle plate square | □ 14 mm

Articolo - Item	V4	V6	VM6	V7	VM7
581.S.C4.20				•	•

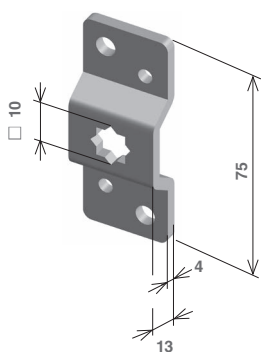

Staffa con foro quadro 10 mm a stella - Interasse
Bracket with a square 10 mm star hole - Pitch | 48/60 mm

Articolo - Item	V4	V6	VM6	V7	VM7
581.S.S0.20	•	•	•		

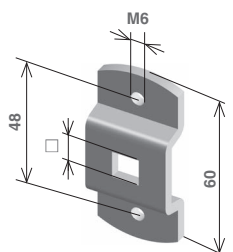

Staffa per tende con foro quadro - Bracket for awnings, square hole | □ 10 mm

Articolo - Item	V4	V6	VM6	V7	VM7
581.S.T0.20	•	•	•		

Staffa per tende con foro quadro - Bracket for awnings, square hole | □ 14 mm

Articolo - Item	V4	V6	VM6	V7	VM7
581.S.T4.20				•	•

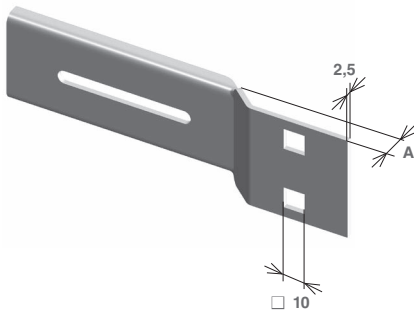

Mensola per supporti "Torino" con fori quadro 10 mm Bracket for "Torino" supports with two square 10 mm holes $A = 11 \text{ mm}$					
Articolo - Item	V4	V6	VM6	V7	VM7
117.A.SA.20	•	•	•		

Mensola per supporti "Torino" con fori quadro 10 mm diritta Bracket for "Torino" supports with two square 10 mm holes $A = 0 \text{ mm}$					
Articolo - Item	V4	V6	VM6	V7	VM7
117.A.SD.20	•	•	•		

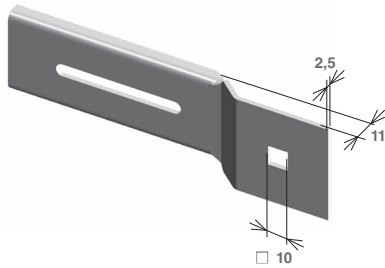

Mensola per supporti "Napoli" con foro quadro 10 mm Bracket for "Napoli" supports with square 10 mm hole					
Articolo - Item	V4	V6	VM6	V7	VM7
117.A.SN.20	•	•	•		

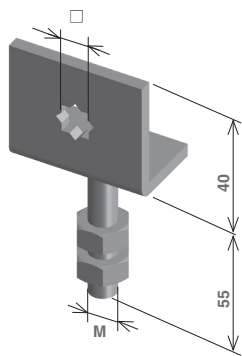

Supporto con foro quadro 10 mm a stella per murature preesistenti Support with square 10 mm star hole for existing embedded supports $M 10$					
Articolo - Item	V4	V6	VM6	V7	VM7
581.S.MS.20	•	•	•		

Supporto con foro quadro 10 mm a stella per murature preesistenti Support with square 10 mm star hole for existing embedded supports $M 12$					
Articolo - Item	V4	V6	VM6	V7	VM7
581.S.2S.20	•	•	•		

Supporto con foro quadro 14 mm a stella per murature preesistenti Support with square 14 mm star hole for existing embedded supports $M 12$					
Articolo - Item	V4	V6	VM6	V7	VM7
581.S.42.20				•	•

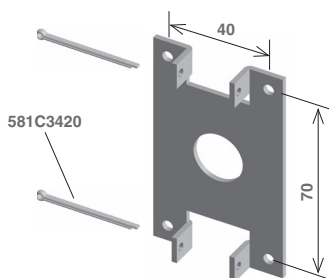

Supporto fissaggio diretto per fianchi in alluminio Direct anchoring support for aluminium end caps					
Articolo - Item	V4	V6	VM6	V7	VM7
581.S.FF.20	•*	•			

Solo in abbinamento a: Use only with: 581MCM90*

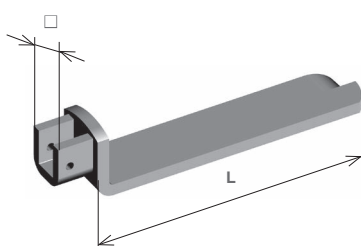

Supporto a murare con sella $\square 10 \text{ mm} - L 118 \text{ mm}$					
Articolo - Item	V4	V6	VM6	V7	VM7
581.S.Z0.20	•	•	•		

Supporto rinforzato a murare con sella Reinf. support to embed with saddle $\square 14 \text{ mm} - L 160 \text{ mm}$					
Articolo - Item	V4	V6	VM6	V7	VM7
581.S.Z4.20				•	•

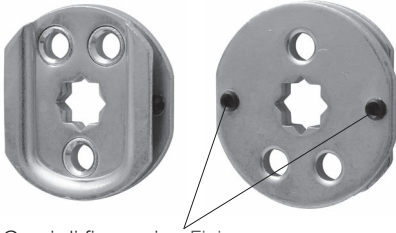

Grani di fissaggio - Fixing screws

Inserto con foro quadro 10 mm a stella per supporto 116.S.11.20 Insert with square 10 mm star hole for support 116.S.11.20					
Articolo - Item	V4	V6	VM6	V7	VM7
116.Q.10.20	•	•	•		

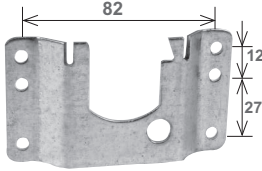

Supporto a legno (piega 11 mm) Screw type support (overhang 11 mm)		
Articolo - Item	Finiture - Finishes	
116.S.11.20	zincato-galvanized	100

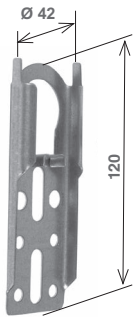

Supporto da avvitare Peso max telo = 60 kg Screw type support Max. weight of the shutter = 60 Kg		
Articolo - Item	Finiture - Finishes	
156.E.00.20	zincato - galvanized	200

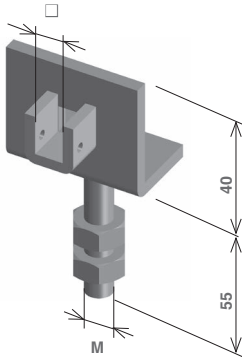

Supporto con sella quadro 10 mm per murature preesistenti Support with square 10 mm saddle for existing embedded supports M10					
Articolo - Item	V4	V6	VM6	V7	VM7
581.S.R0.20	•	•	•		

Supporto con sella quadro 10 mm per murature preesistenti Support with square 10 mm saddle for existing embedded supports M12					
Articolo - Item	V4	V6	VM6	V7	VM7
581.S.R2.20	•	•	•		

Supporto con sella quadro 14 mm per murature preesistenti Support with square 14 mm saddle for existing embedded supports M12					
Articolo - Item	V4	V6	VM6	V7	VM7
581.S.R4.20				•	•

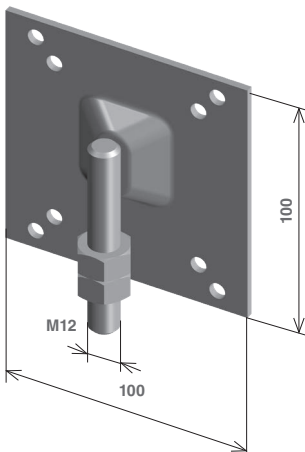

Supporto per collegamento muratura preesistente Support for linking an existing embedded support					
Articolo - Item	V4	V6	VM6	V7	VM7
301.S.MU.20		•	•	•	•



Supporto con foro quadro 10 mm per cassonetti prefabbricati
Support with square 10 mm hole for thermo-insulated boxes

Articolo - Item	V4	V6	VM6	V7	VM7
303.S.C0.20	•	•	•		



Supporto con foro quadro 10 mm a stella
Support with square 10 mm star hole

Articolo - Item	V4	V6	VM6	V7	VM7
303.S.CS.20	•	•	•		

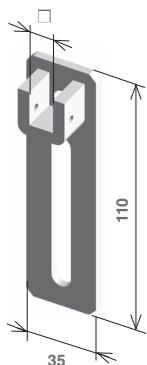

Supporto verticale asolato con sella quadro
Slotted vertical support with saddle square | □ 10 mm

Articolo - Item	V4	V6	VM6	V7	VM7
581.S.V0.20	•	•	•		

Supporto verticale asolato con sella quadro
Vertical support with saddle square | □ 14 mm

Articolo - Item	V4	V6	VM6	V7	VM7
581.S.V4.20				•	•

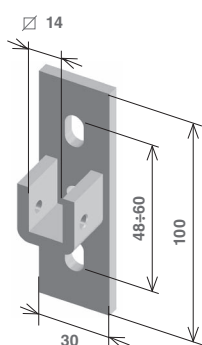

Supporto verticale con sella quadro centrata
Vertical support with central saddle | □ 14 mm

Articolo - Item	V4	V6	VM6	V7	VM7
581.S.A4.20				•	•

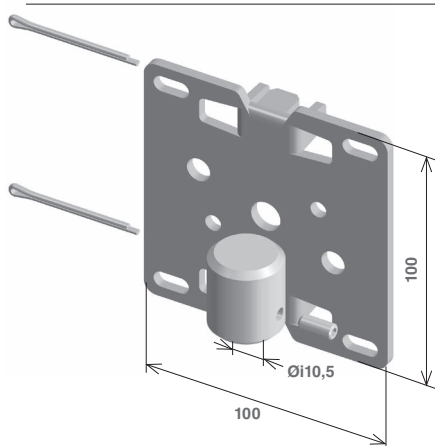

Supporto fissaggio diretto con boccola foro 10,5 mm
Direct anchoring support with hole 10,5 mm bushing

Articolo - Item	V4	V6	VM6	V7	VM7
581.S.F9.20		•	•*	•	•**

Solo in abbinamento a: / Use only with: 581R0070* - 581R0770**

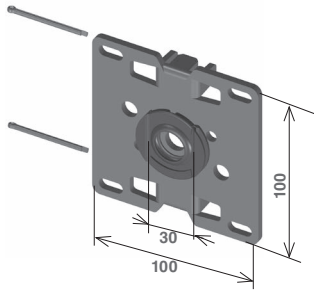

Supporto fissaggio diretto con incastro posteriore Direct anchoring support rear dap joint					
Articolo - Item	V4	V6	VM6	V7	VM7
581.S.FI.20		•	•*	•	•**

Solo in abbinamento a: / Use only with: 581R0070* - 581R0770**

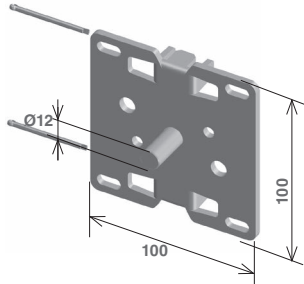

Supporto fissaggio diretto con perno per cuscinetto Direct anchoring support with pivot for bearing					
Articolo - Item	V4	V6	VM6	V7	VM7
581.S.FP.20		•	•*	•	•**

Solo in abbinamento a: / Use only with: 581R0070* - 581R0770**

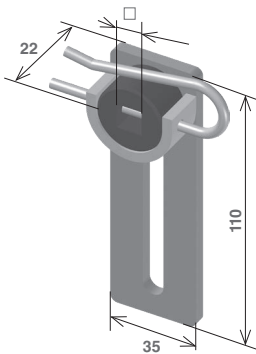

Supporto verticale asolato con sblocco - quadro 10 mm Slotted vertical support with unlock pin - square 10 mm					
Articolo - Item	V4	V6	VM6	V7	VM7
581.S.B0.20	•	•	•		

Supporto verticale asolato con sblocco - quadro 14 mm Slotted vertical support with unlock pin - square 14 mm					
Articolo - Item	V4	V6	VM6	V7	VM7
581.S.B4.20				•	•

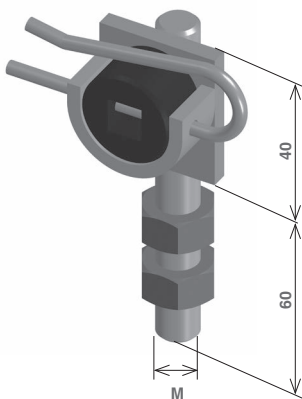

Supporto con foro quadro 10 mm e sblocco per murature preesistenti Support with square 10 mm hole and unlock pin for existing embedded supports					
Articolo - Item	V4	V6	VM6	V7	VM7
581.S.D0.20	•	•	•		

Supporto con foro quadro 10 mm e sblocco per murature preesistenti Support with square 10 mm hole and unlock pin for existing embedded supports					
Articolo - Item	V4	V6	VM6	V7	VM7
581.S.D2.20	•	•	•		

Supporto con foro quadro 14 mm e sblocco per murature preesistenti Support with square 14 mm hole and unlock pin for existing embedded supports					
Articolo - Item	V4	V6	VM6	V7	VM7
581.S.D4.20				•	•

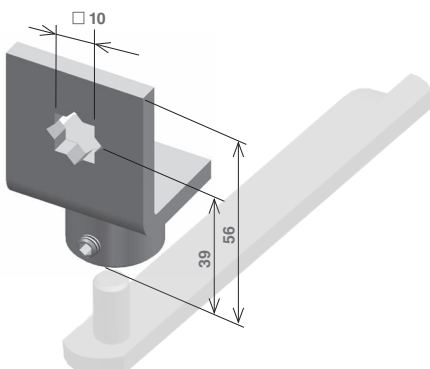

Supporto con foro quadro 10 mm a stella con boccia foro 10,5 mm Support with 10 mm star-shaped square hole with 10.5 mm bush sleeve					
Articolo - Item	V4	V6	VM6	V7	VM7
581.S.M9.20	•	•			



□□ = GR (Grigio - Grey)

□□ = VE (Verde - Green)

□□ = BL (Blu - Blue)

□□ = RO (Rosso - Red)

Mirò

Trasmittitore a 1 canale (433,42 MHz)
Radio transmitter - 1 channel (433,42 MHz)

Articolo - Item

595.T.X1.00. □□

Alimentazione Power supply	Vdc	1x3 tipo type CR2032
Frequenza di lavoro Operating frequency	MHz	433,42
Temperatura di esercizio Operating temperature	°C	-20 ÷ +55
Dimensioni Dimensions	mm	30 x 100 x 15

V4 / V6 / VM6	V6RX.3 / VM6RX.3	V6RX.E3	V7 / VM7	V7RX.3	V7RX.E3
	•	•		•	•



□□ = GR (Grigio - Grey)

□□ = VE (Verde - Green)

□□ = BL (Blu - Blue)

□□ = RO (Rosso - Red)

Botero

Trasmittitore a 6 canali (433,42 MHz)
Radio transmitter - 6 channels (433,42 MHz)

Articolo - Item

596.T.X6.00. □□

Alimentazione Power supply	Vdc	1 tipo type CR2032
Frequenza di lavoro Operating frequency	MHz	433,42
Temperatura di esercizio Operating temperature	°C	-20 ÷ +55
Dimensioni Dimensions	mm	46 x 147 x 16

Trasmittitore a 15 canali (433,42 MHz)
Radio transmitter - 15 channels (433,42 MHz)

Articolo - Item

596.T.X5.00. □□

Alimentazione Power supply	Vdc	1 tipo type CR2032
Frequenza di lavoro Operating frequency	MHz	433,42
Temperatura di esercizio Operating temperature	°C	-20 ÷ +55
Dimensioni Dimensions	mm	46 x 147 x 16

V4 / V6 / VM6	V6RX.3 / VM6RX.3	V6RX.E3	V7 / VM7	V7RX.3	V7RX.E3
	•	•		•	•

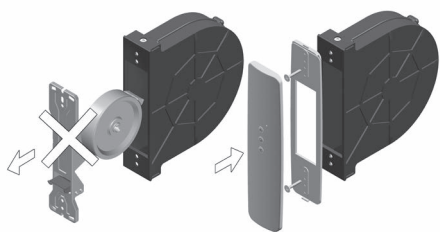

Venus RX

Placca Venus RX con trasmettitore a 1 canale (433,42 MHz)
RX Venus cover with transmitter 1 channel (433,42MHz)

Articolo - Item

595.P.X1 □□

Alimentazione Power supply	Vdc	1x3 tipo type CR2032
Frequenza di lavoro Operating frequency	MHz	433,42
Temperatura di esercizio Operating temperature	°C	-20 ÷ +55
Dimensioni Dimensions	mm	58 x 230 x 10

V4 / V6 / VM6	V6RX.3 / VM6RX.3	V6RX.E3	V7 / VM7	V7RX.3	V7RX.E3
	•	•		•	•

Predisposizione per interassi 142 mm, 165 mm, 184 mm, 206 mm
Suitable for hole pitch 142 mm, 165 mm, 184 mm, 206 mm

Codice finale - Final code	Finiture - Finishes
□□ = 93	Bianco - White
□□ = 9A	Alluminio - Aluminium



□□ = GR (Grigio - Grey)

□□ = VE (Verde - Green)

□□ = BL (Blu - Blue)

□□ = RO (Rosso - Red)

Picasso

Pulsantiera RX a 1 canale (433,42 MHz)
RX push button 1 channel (433,42MHz)

Articolo - Item

595.M.X1.00. □□

Alimentazione Power supply	Vdc	1x3 tipo type CR2032
Frequenza di lavoro Operating frequency	MHz	433,42
Temperatura di esercizio Operating temperature	°C	-20 ÷ +55
Dimensioni Dimensions	mm	80 x 80 x 15

V4 / V6 / VM6	V6RX.3 / VM6RX.3	V6RX.E3	V7 / VM7	V7RX.3	V7RX.E3
	•	•		•	•



595.T.X1.00

596.R.EU.00

- = GR (Grigio - Grey)
- = VE (Verde - Green)
- = BL (Blu - Blue)
- = RO (Rosso - Red)

Kit ricevitore + trasmettitore per radiocomando diretto di 1 motore (433,42 MHz) Remote control kit to directly operate 1 motor (433,42 MHz)	
Articolo - Item	
595.K.E1.00. □□	

Alimentazione Power supply	Vac/Hz	120-230@50/60
Portata contatto Contact capacity	A	10 A @ 250 Vac
Frequenza di lavoro Operating frequency	MHz	433,42
Temperatura di esercizio Operating temperature	°C	-20 ÷ +55
Grado di protezione Protection degree	IP	20
Tempo di lavoro Working time	sec.	5-240
Dimensioni Dimensions	mm	84 x 40 x 26
Consumo a riposo Stand-by consumption	W	< 0,5

Alimentazione Power supply	Vdc	1 tipo type CR2032
Frequenza di lavoro Operating frequency	MHz	433,42
Temperatura di esercizio Operating temperature	°C	-20 ÷ +55
Dimensioni Dimensions	mm	30 x 100 x 15

V4 / V6 / VM6	V6RX.3 / VM6RX.3	V6RX.E3	V7 / VM7	V7RX.3	V7RX.E3
•			•		

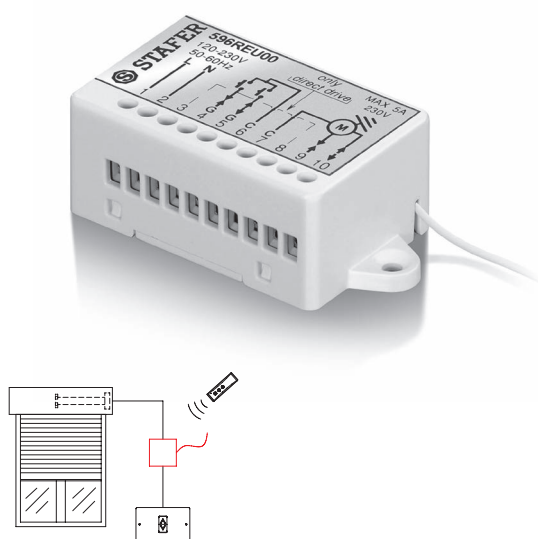

Gold

Ricevitore per azionamento diretto di 1 motore (433,42 MHz) Radio receiver for direct operation of 1 motor (433,42 MHz)	
Articolo - Item	
596.R.EU.00	

Alimentazione Power supply	Vac/Hz	120-230@50/60
Portata contatto Contact capacity	A	10 A @ 250 Vac
Frequenza di lavoro Operating frequency	MHz	433,42
Temperatura di esercizio Operating temperature	°C	-20 ÷ +55
Grado di protezione Protection degree	IP	20
Tempo di lavoro Working time	sec.	5-240
Dimensioni Dimensions	mm	84 x 40 x 26
Consumo a riposo Stand-by consumption	W	< 0,5

V4 / V6 / VM6	V6RX.3 / VM6RX.3	V6RX.E3	V7 / VM7	V7RX.3	V7RX.E3
•			•		

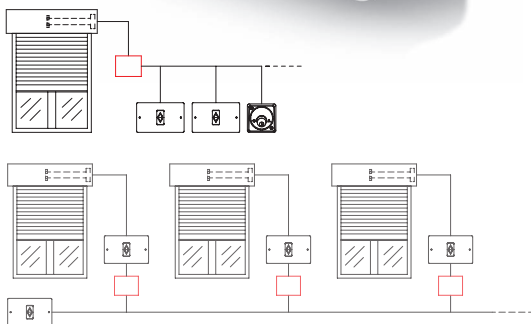

Link

Modulo di centralizzazione con ritardo programmabile Centralization module with adjustable lag

Articolo - Item

596.M.UM.00

Alimentazione Power supply	Vac/Hz	120-230@50/60
Portata contatto Contact capacity	A	10 A @ 250 Vac
Tempo di lavoro Working time	sec.	5-240
Temperatura di esercizio Operating temperature	°C	-20 ÷ +55
Grado di protezione Protection degree	IP	20
Dimensioni Dimensions	mm	84 x 40 x 26
Consumo a riposo Stand-by consumption	W	< 0,5

V4 / V6 / VM6	V6RX.3 / VM6RX.3	V6RX.E3	V7 / VM7	V7RX.3	V7RX.E3
•			•		

Fox

Modulo di centralizzazione e distribuzione Centralization and distribution module

Articolo - Item

596.C.SR.00

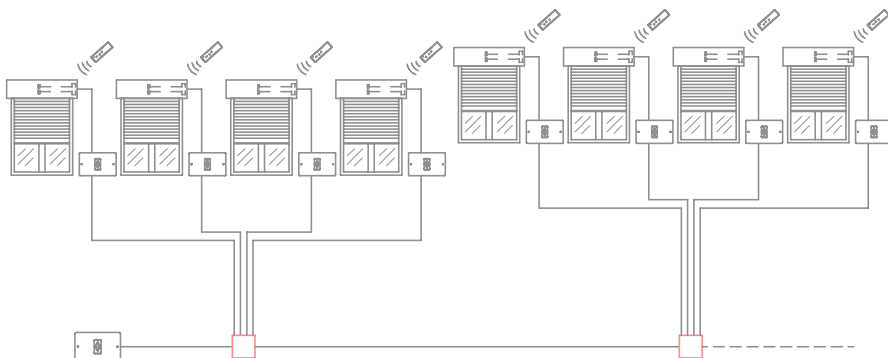

Temperatura di esercizio Operating temperature	°C	-20 ÷ +55
Grado di protezione Protection degree	IP	20
Corrente massima Max current	mA	100
Dimensioni Dimensions	mm	84 x 40 x 26

V4 / V6 / VM6	V6RX.3 / VM6RX.3	V6RX.E3	V7 / VM7	V7RX.3	V7RX.E3
	•	•		•	•

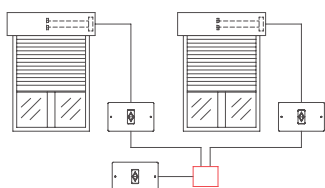

Eco 2

**Modulo di raggruppamento elettromeccanico A RELE' per 1 o 2 motori
Grouping electro-mechanical module for 1 or two motors**

Articolo - Item

590.M.R1.00

Alimentazione Power supply	Vac/Hz	230/50
Portata contatto Contact capacity	A	5 A @ 250 Vac
Temperatura di esercizio Operating temperature	°C	-20 ÷ +55
Grado di protezione Protection degree	IP	20
Dimensioni Dimensions	mm	84 x 40 x 26

V4 / V6 / VM6	V6RX.3 / VM6RX.3	V6RX.E3	V7 / VM7	V7RX.3	V7RX.E3
•			•		

Eco 4

**Modulo di raggruppamento elettromeccanico A RELE' per 4 motori
Grouping electro-mechanical module for 4 motors**

Articolo - Item

590.M.R4.00

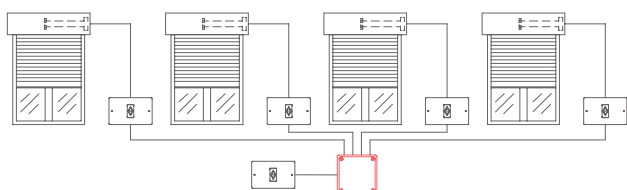

Alimentazione Power supply	Vac/Hz	230/50
Portata contatto Contact capacity	A	4 x 5 A @ 250 Vac
Temperatura di esercizio Operating temperature	°C	-20 ÷ +55
Grado di protezione Protection degree	IP	55
Dimensioni Dimensions	mm	100 x 100 x 60

V4 / V6 / VM6	V6RX.3 / VM6RX.3	V6RX.E3	V7 / VM7	V7RX.3	V7RX.E3
•			•		

Sunny

La soluzione smart per i tuoi avvolgibili!
Scarica la nuova App **Stafer Home**

The smart solution for your rolling shutters!
Download the new **Stafer Home** App



Con la nuova App Stafer Home puoi movimentare i tuoi avvolgibili con smartphone, con gli assistenti vocali e anche da remoto

With the new Stafer Home App you can move your rolling shutters by smartphone, by voice assistants and even remotely



STAFERHOME

Compatibile anche con radiocomandi Stafer
Also compatible with Stafer radio controls

Sunny



Centralina DOMOTICA WiFi per azionamento di 1 motore SMART WiFi module for operation of 1 motor

Articolo - Item

597.M.WT.00

Alimentazione Power supply	Vac/Hz	220-240 @ 50/50
Portata contatto Contact capacity	A	3A @ 250 Vac
Frequenza di lavoro WiFi	GHz	2,4 / 2,4835
Temp. di esercizio Operating temperature	°C	-10 ÷ +55
Grado di protezione Protection degree	IP	20
Tempo di lavoro Working time	sec.	1 - 60
Dimensioni Dimensions	mm	46 x 46 x 18
Consumo a riposo Stand-by consumption	W	< 0,5



STAFERHOME



Modulo di comando elettronico per 2 motori sincronizzati Electronic command module for 2 synchronized motors

Articolo - Item

590.S.2M.00

Alimentazione Power supply	Vac/Hz	230@50
Temperatura di esercizio Operating temperature	°C	-10 ÷ +55
Dimensioni Dimensions	mm	110 x 150 x 50
Grado di protezione Protection degree	IP	54

V4 / V6 / VM6	V6RX.3 / VM6RX.3	V6RX.E3	V7 / VM7	V7RX.3	V7RX.E3
•			•		

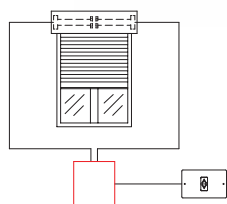

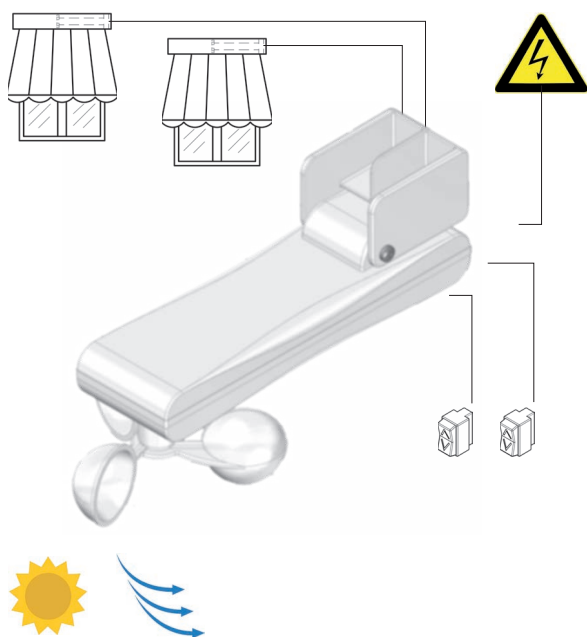

Senio

Controllo sole-vento con centralina integrata per comando a pulsante per 1 o 2 motori
Integrated sun-wind control for push button operation for 1 or 2 motors

Articolo - Item

595.K.F2.00

Alimentazione Power supply	Vac/Hz	120-230@50/60
Portata contatto Contact capacity	A	2 x 10 A @ 250 Vac
Soglia vento Wind threshold	Km/h	10 ÷ 35
Soglia sole Sun threshold	Klux	1 ÷ 45
Consumo a riposo Stand-by consumption	W	< 0,5
Temperatura di esercizio Operating temperature	°C	-20 ÷ +55
Dimensioni Dimensions	mm	238 x 110 x 116

V4 / V6 / VM6	V6RX.3 / VM6RX.3	V6RX.E3	V7 / VM7	V7RX.3	V7RX.E3
•			•		

Soglia sole e vento regolabile da pulsante a muro
Sun and wind threshold adjustable through buttons on wall

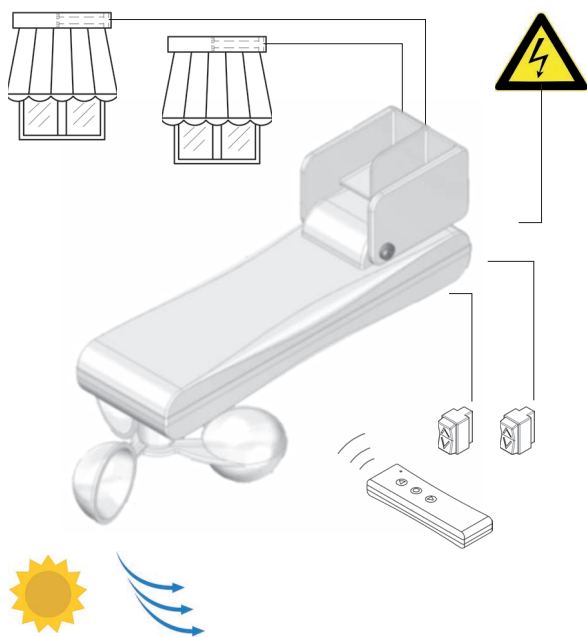

Sillaro

Controllo sole-vento radiocomandato integrato per 1 o 2 motori (433,42 MHz)
Integrated sun-wind radio control for 1 or 2 motors (433,42 MHz)

Articolo - Item

595.K.RS.00

Alimentazione Power supply	Vac/Hz	120-230@50/60
Portata contatto Contact capacity	A	10 A @ 250 Vac
Frequenza di lavoro Operating frequency	MHz	433,42
Soglia vento Wind threshold	Km/h	10 ÷ 35
Soglia sole Sun threshold	Klux	1 ÷ 45
Consumo a riposo Stand-by consumption	W	< 0,5
Temperatura di esercizio Operating temperature	°C	-20 ÷ +55
Dimensioni Dimensions	mm	238 x 110 x 116

V4 / V6 / VM6	V6RX.3 / VM6RX.3	V6RX.E3	V7 / VM7	V7RX.3	V7RX.E3
•			•		

Soglia sole e vento regolabile da pulsante a muro e da radiocomando
Sun and wind threshold adjustable through buttons on wall and by radio transmitter

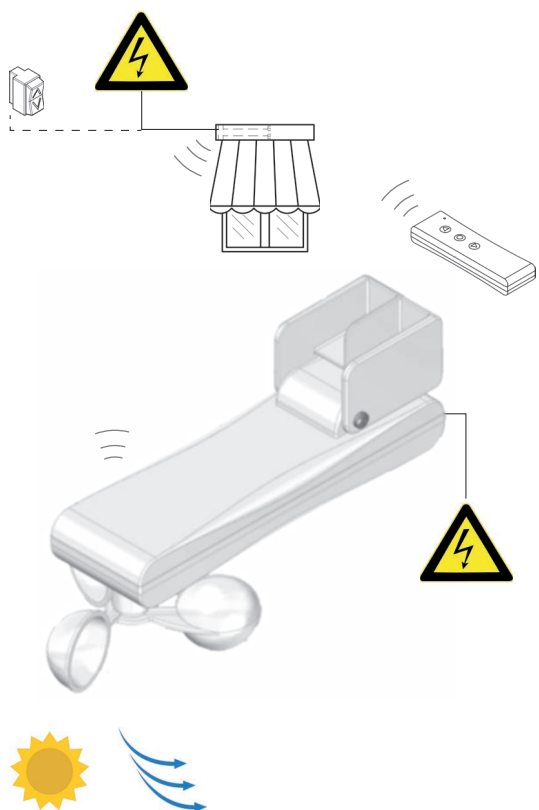

Reno

**Radio controllo sole-vento integrato
per uno o più motori (433,42 MHz)
Integrated radio sun-wind control
for one or several motors (433,42 MHz)**

Articolo - Item

595.K.XS.00

Alimentazione Power supply	Vac/Hz	120-230@50/60
Frequenza di lavoro Operating frequency	MHz	433,42
Soglia vento Wind threshold	Km/h	10 ÷ 35
Soglia sole Sun threshold	Klux	1 ÷ 45
Consumo a riposo Stand-by consumption	W	< 0,5
Temperatura di esercizio Operating temperature	°C	-20 ÷ +55
Dimensioni Dimensions	mm	238 x 110 x 116

V4 / V6 / VM6	V6RX.3 / VM6RX.3	V6RX.E3	V7 / VM7	V7RX.3	V7RX.E3
	•	•		•	•

Soglia sole e vento regolabile da pulsante a muro e da radiocomando
Sun and wind threshold adjustable through buttons on wall and by radio transmitter

Può essere montato un motore NON radio abbinandolo ad un ricevitore 596REU00
A NON radio motor can be mounted using a 596REU00 receiver

Lo stesso sensore può comandare più motori
The sensor can control multiple motors

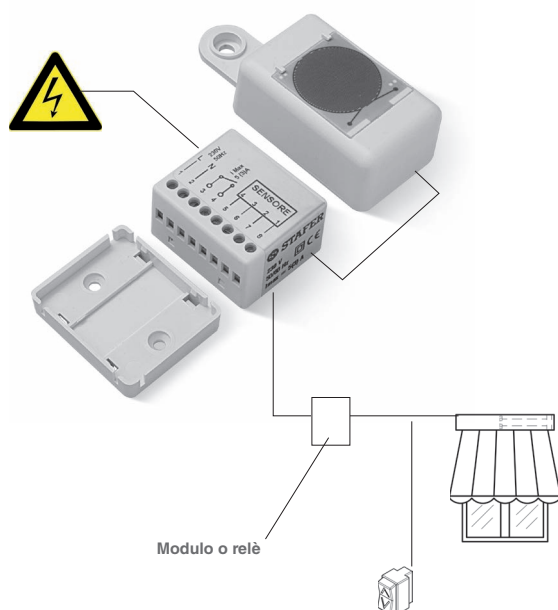

Kit sensore pioggia con alimentatore Rain sensor + power supply

Articolo - Item

591.K.SP.00

Alimentazione Power supply	Vac/Hz	230@50
Portata contatto Contact capacity	A	5 A @ 250 Vac
Corrente erogabile Max output current	mA	25
Temperatura di esercizio Operating temperature	°C	-20 ÷ +55
Grado di protezione Protection degree	IP	20
Dimensioni Dimensions	mm	44 x 38 x 25

Alimentazione Power supply	Vac/dc	12
Portata contatto Contact capacity	mA	100 mA @ 12 Vac/dc
Consumo a riposo Stand-by consumption	mA	10
Temperatura di esercizio Operating temperature	°C	-20 ÷ +55
Grado di protezione Protection degree	IP	55
Dimensioni Dimensions	mm	63 x 39 x 29

V4 / V6 / VM6	V6RX.3 / VM6RX.3	V6RX.E3	V7 / VM7	V7RX.3	V7RX.E3
•			•		

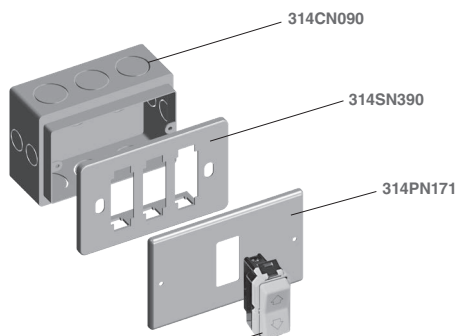

314B0000 = pos. stab.
314B0M00 = pos. moment.

Kit pulsantiera posizioni stabili Push button kit (stable positions)	
Articolo - Item	Nota - Note
314.K.00.71	No per motori RX - Not for RX motors

Kit pulsantiera posizioni momentanee Push button kit (momentary positions)	
Articolo - Item	
314.K.PM.71	

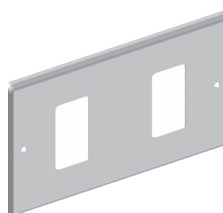

Placca in alluminio a due fori Aluminium switch cover plate, two holes	
Articolo - Item	
314.P.N2.71	

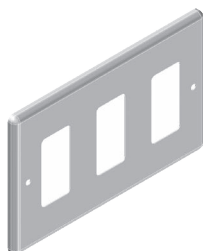

Placca in alluminio a tre fori Aluminium switch cover plate, three holes	
Articolo - Item	
314.P.N3.71	

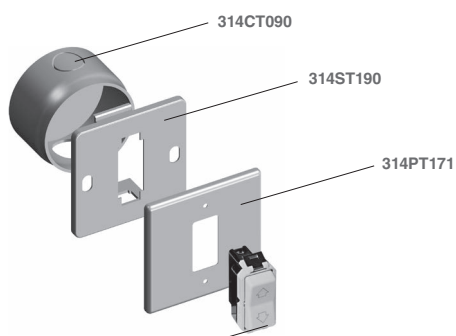

314B0000 = pos. stab.
314B0M00 = pos. moment.

Kit pulsantiera piccola posizioni stabili Small push button kit (stable positions)	
Articolo - Item	Nota - Note
314.K.T0.71	No per motori RX - Not for RX motors

Kit pulsantiera piccola posizioni momentanee Small push button kit (momentary positions)	
Articolo - Item	
314.K.TM.71	

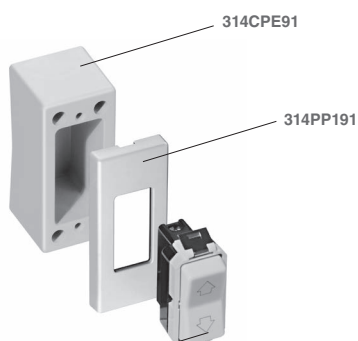

314B0000 = pos. stab.
314B0M00 = pos. moment.

Kit pulsantiera esterna posizioni stabili External push button kit (stable positions)	
Articolo - Item	Nota - Note
314.K.E0.91	No per motori RX - Not for RX motors

Kit pulsantiera esterna posizioni momentanee External push button kit (momentary positions)	
Articolo - Item	
314.K.EM.91	



314.E.PM.93

314.E.PS.93

Pulsantiera esterna in plastica 2 tasti, con cornice
External plastic 2-keys push-button, with frame

Articolo - Item	Nota - Note
314.E.PM.93	Posizioni momentanee Momentary positions
314.E.PS.93	Posizioni stabili stable positions

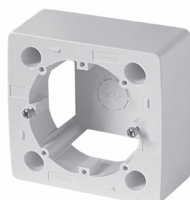

Cassetta esterna per pulsantiera esterna in plastica a 2 tasti
External box for external plastic 2-keys push-button

Articolo - Item
314.C.EP.93

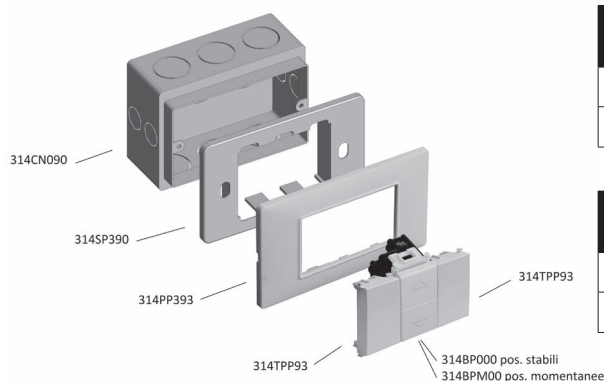

Kit pulsantiera posizioni stabili placca in plastica
Push button kit (stable positions)

Articolo - Item	Nota - Note
314.K.00.93	No per motori RX - Not for RX motors

Kit pulsantiera posizioni momentanee in plastica
Push button kit (momentary positions)

Articolo - Item
314.K.PM.93



Selettore chiave da incasso
Key switch to embed

Articolo - Item
315.K.00.00



Selettore chiave esterno
External key switch

Articolo - Item
315.K.E0.00



Pulsantiera per installazione rapida di motori "normali" e RADIO
Push button for quick installation of motors "normal" and RADIO

Articolo - Item
582.C.PM.00



Cavo elettrico 4 x 0,75 mm in rotoli da 50 m
4 x 0,75 mm electrical wire 50 m rolls

Articolo - Item
582.R.40.00

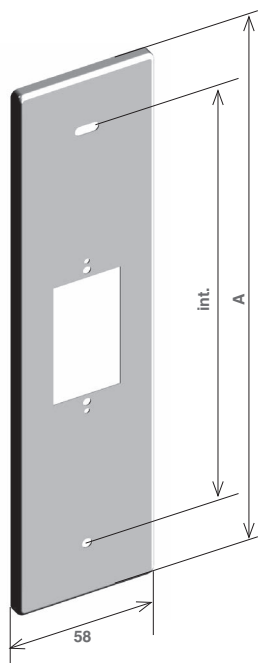

Placca - Cover <i>int</i> = 142 mm – <i>A</i> = 205 mm
<i>Articolo - Item</i>
007.P.F4.□□

Placca - Cover <i>int</i> = 165 mm – <i>A</i> = 205 mm
<i>Articolo - Item</i>
007.P.F6.□□

Placca - Cover <i>int</i> = 184 mm – <i>A</i> = 232 mm
<i>Articolo - Item</i>
015.P.F8.□□

Placca - Cover <i>int</i> = 206 mm – <i>A</i> = 232 mm
<i>Articolo - Item</i>
015.P.F0.□□

<i>Codice finale - Final code</i>	<i>Finiture - Finishes</i>
□□ = 30	Inox - Stainless steel
□□ = 70	Alluminio grezzo - Raw Aluminium
□□ = 71	Alluminio anodizzato argento - Alu. silver anodized
□□ = 72	Alluminio bronzato - Alu. bronze anodized
□□ = 77	Alluminio plastificato bianco RAL 9010 - Alu. white coated RAL 9010
□□ = 78	Alluminio plastificato nero RAL 9005 - Alu. black coated RAL 9005
□□ = 79	Alluminio color oro - Alu. gold colour

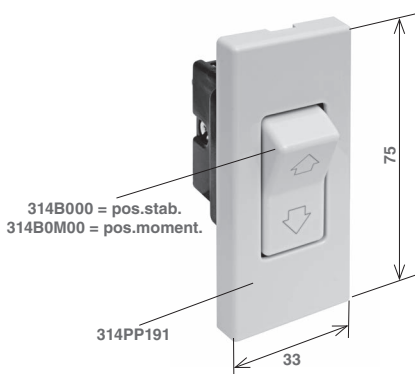

Pulsantiera posizioni stabili Push button (stable positions)	
<i>Articolo - Item</i>	<i>Nota - Note</i>
313.K.00.91	No per motori RX - Not for RX motors

Pulsantiera posizioni momentanee Push button (momentary positions)	
<i>Articolo - Item</i>	
313.K.PM.91	



Placca cieca per sostituzioni Blind cover plate for replacement	
Per i modelli disponibili vedere pag. 60/62	
For available models see page 60/762	



Placca - Cover <i>int</i> = 142 mm – A = 205 mm
<i>Articolo - Item</i>
007.P.V4.□□

Placca - Cover <i>int</i> = 165 mm – A = 205 mm
<i>Articolo - Item</i>
007.P.V6.□□

Placca - Cover <i>int</i> = 184 mm – A = 232 mm
<i>Articolo - Item</i>
015.P.V8.□□

Placca - Cover <i>int</i> = 206 mm – A = 232 mm
<i>Articolo - Item</i>
015.P.V0.□□

Codice finale - Final code	Finiture - Finishes
□□ = 30	Inox - Stainless steel
□□ = 71	Alluminio anodizzato argento - Alu. silver anodized
□□ = 77	Alluminio plastificato bianco RAL 9010 - Alu. white coated RAL 9010

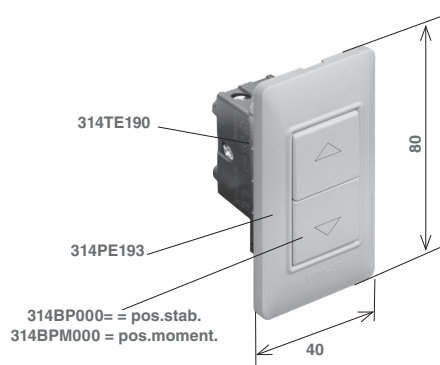

Pulsantiera posizioni stabili Push button (stable positions)	
<i>Articolo - Item</i>	<i>Nota - Note</i>
314.K.V0.93	No per motori RX - Not for RX motors

Pulsantiera posizioni momentanee Push button (momentary positions)	
<i>Articolo - Item</i>	
314.K.VM.93	